



# FILL-RITE®

## Operation and Safety Manual TT10A In-line Turbine Meter



Dear Tuthill Customer,

Thank you for buying a Tuthill product. Tuthill represents a new age in transfer and measuring equipment. This manual contains valuable information about your new equipment and its operating and service requirements. Please take a few minutes to review this material carefully.

Tuthill's mission is to provide fluid handling systems that deliver the most accurate, safe, convenient, and economical transfer systems for users of fuels.

If, for any reason, any of the products do not meet your performance expectations, we want to hear from you.

Your comments and suggestions are requested and appreciated. Thank you again for buying a Tuthill product. We look forward to serving you in the future.

The Tuthill Team 1-800-634-2695

## CAUTION!

Wear proper safety equipment when handling hazardous fluids.

## TT10A (Fuels) Technical Information

Flow Ports	1" NPT or BSPP female inlet and outlet ports
Flow Range	2 to 35 U.S. GPM / 7.6 to 132.5 LPM
Working Pressure	50 PSI (3.4 Bar) MAX UL 300 PSI (20.7 Bar) Burst
Storage Temperature	-40°F to 176°F (-40°C to 60°C) (No Liquids)
Operating Temperature	-40°F to 176°F (-40°C to 60°C)
Measurement Accuracy	±1.0% (After field calibration)
Measurement Repeatability	±0.30% (Batch sizes ≥ 2 Gallons)
Measurement Units	Ounce, Pint, Quart, Liter, Gallon
Totalizer Range	0 - 90,000,000 Units
Batch Range	0.00 - 9999 Units ( <i>Blinks when Batch exceeds 9999</i> )
Wetted Materials	304/316 Stainless Steel, Aluminum Acetal, Gold
Display	-40°F to 176°F (-40°C to 60°C)
Power	2 approved alkaline batteries. See battery replacement section of the manual
Memory	Meter totals and calibration are preserved when replacing batteries
Safety	Intrinsically safe electronics for use in hazardous locations.

## Safety Instructions

To ensure safe and efficient operation, it is essential to read and follow each of the following warnings and precautions.

1. Fuels and Chemicals flowing through the meter may be harmful to your health. Use and disposal of these products is controlled by federal, state, or local laws and procedures.
2. Conform to fluid manufacturer's recommended handling procedures when using product and when cleaning meter.
3. Do not exceed an internal meter pressure of 50 PSI (3.5 Bar) for the TT10A models and 125 PSI (8.6 Bar) for the TT10P models.
4. Improper use or installation of this product can cause serious bodily injury or death.
5. Ensure the piping and hoses connected to the meter are properly grounded when metering or using near flammable fluids.
6. **DO NOT** install additional foot or check valves without use of a pressure relief valve; otherwise the meter may rupture.
7. To avoid build up of electrostatic discharge, please clean with damp cloth only.
8. The meter body is made of aluminum alloy. Avoid impact or friction on meter body.

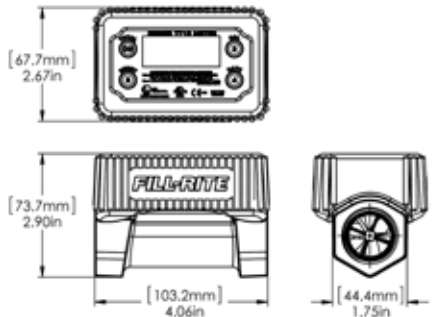

## General Description

The TT10 Series Meters are electronic turbine meters suitable for use in Hazardous Locations and extreme temperatures.

The TT10 Meters feature advanced electronics that eliminate false counts in high vibration and mobile applications without sacrificing the ability to meter at low flows.

The meter can store and display the current metered amount (batch total), or cumulative metered amount (totalizer) in any of five user selectable units (ounces, pints, quarts, liters, and gallons).

The meter may be easily adjusted for different fluids by selecting a calibration factor from one of 20 settings.

Power is supplied by two replaceable AA alkaline batteries.

## Fluid / Viscosity Compatibility

The TT10A Series meters will handle most fuels with viscosities in the range of 0.4 cSt to 79 cSt.

You may meter fluids that exceed a viscosity of 79 cSt, but accuracy will be limited to the calibration flow rate. Set the meter for CAL 19 and follow the calibration described in this manual.

If in doubt about compatibility of a specific fluid, contact the supplier of the fluid to check for any adverse reactions to the listed materials in the Technical Information section of this manual.

### Approved Fluids:

- Gasoline
- Diesel
- Kerosene
- Hexane
- Heptane
- Mineral Spirits
- Non-potable fresh water

## Installation

### Installation Hints

Excess sealant tape or thread compound upstream of the meter can break free and jam or impair the rotor and cause meter failure. Use of an appropriate amount of thread compound is the preferred method of installation.

Use a compatible sealant tape or thread compound on all threaded joints.

1. Determine correct direction for fluid flow and point the arrow on the underside of the meter body in that direction. *Installing the meter in the wrong direction of flow will significantly impact the performance of the meter.*

2. Thread the hose or pipe into ports until snug. Be careful not to cross thread when starting threads or over-tighten the meter.

## Electronic Module Orientation

The Display can be oriented for right-to-left or left-to-right flow.

1. Peel off the protective rubber boot and set aside.
2. Remove the 4 screws holding on the electronic module using a T-20 Torx driver.
3. Remove the module and rotate 180°. Ensure that the foam pad under the batteries is reinstalled correctly if it falls out. This is critical to ensure the batteries are not dislodged if the meter is exposed to rough handling.
4. Reinstall the 4 screws. They should be tight enough to fully seat the module. The recommended installation torque is 5-10 in-lb (0.6-1.1 Nm). *Over-tightening may crack the module.*
5. Reinstall the protective rubber boot.

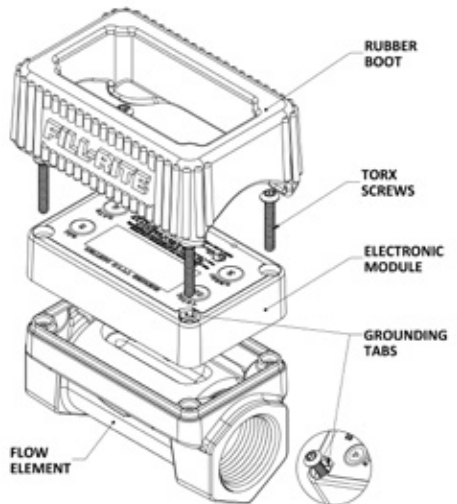

### ⚠ CAUTION!

When reinstalling the screws for the electronic module, ensure the grounding tabs are captured under the heads of the screws. This ensures proper ground and protection against static discharge when handling the meter.

## Operational Functions

<b>TOTAL ON</b>	<ul style="list-style-type: none"> <li>Turns meter on.</li> <li>Displays accumulated total while pressed. If the accumulated total is larger than 9999, the numbers will scroll across the screen in groups of 4 digits.</li> </ul>
<b>RESET 2</b>	When held for 3 seconds, it resets the current total to zero. Also reverts to normal operating mode when in CAL or FLSH mode.
<b>CAL 3</b>	When held for 3 seconds, it allows changes to the calibration/fluid factor displayed in the bottom left corner. Repeated activation will increment the number up to 19 and then back to zero. When the desired number is displayed, press button <b>2</b> to lock in the new number and return to normal operation. Please reference Table 1 for specifics.
<b>RATE 4</b>	When held for 3 seconds, the RATE icon is displayed. The active flow rate will be displayed. Press button <b>4</b> again to resume normal operation. The meter will continue to count volume while flow rate is displayed.

### NOTE

The meter display will automatically turn off after 30 seconds of inactivity to conserve batteries. It will turn on when flow resumes or any button is pushed. No data is lost during periods of inactivity.

## Changing Units of Measure

The units of measure can be changed to ounces (OZ), pints (PT), quarts (QT), gallons (GAL), or liters (LITER) without recalibrating the meter.

- Hold buttons **2** and **4** for three seconds. The display will show the firmware version.
- Press button **3**. The display will show the current unit.
- To change units, press the **ON** button repeatedly until the desired unit is displayed.
- Press button **2** to lock in the selection. The display will show the firmware version.
- To return to normal operating mode press button **2** again.
- The units selected will be displayed. Current or accumulated total will be updated to reflect the new unit of measure.

## Press Calibration/Fluid Type Factor (CAL)

The TT10 Series Meters provide 20 preset factors for different fluid types/viscosities.

Use of calibration factors is intended to provide the most accurate metering solution for a specific fluid. A CAL factor of 0 is for use with the thinnest fluids and increases for higher viscosity fluids.

- Press and hold button **3** for 3 seconds. The current dispensed count value will disappear and only the CAL icon and the current value will be displayed.
- Repeatedly pushing button **3** will increment the number up to 19 and then back to zero.
- After the desired fluid factor has been selected, press button **2** to lock in the fluid factor and return the meter to normal operating mode.

*CAL Factors and viscosities shown in the table below are for fluids at 70°F / 21°C.*

Cal	0	1	2	3	4	5	6	7	8	9
cSt	0.36	0.48	0.63	0.84	1.12	1.48	1.98	2.62	3.48	4.62
Fluid	Heptane		Gasoline		Water / DEF		Mineral Spirits	Kerosene	Diesel	B100
Cal	10	11	12	13	14	15	16	17	18	19
cSt	6.15	8.16	10.8	14.4	19.1	25.4	33.7	44.8	59.5	79.0
Fluid		Jet Fuel			Ethylene Glycol				Propylene glycol	10W-30 Oil / ATF

Table 1: CAL Factor Table

### NOTE

Use of the CAL/Fluid factor is independent from performing a calibration against a known volume. The meter is calibrated at the factory, but performing a field calibration may further improve meter accuracy.

## Fluid Calibration

Fluid calibration requires a container of a known volume at least 5 gallons or larger that is compatible with the fluid being metered.

A larger volume may be used and may improve calibration accuracy, but do not exceed 99.99 units of measure.

### NOTE

Before performing a fluid calibration, ensure you have selected the closest matching CAL/Fluid factor to ensure the best meter accuracy.

1. Press the **[2]** & **[4]** buttons at the same time and hold for 3 seconds. The display will show the firmware version.
2. Press button **[3]** to enter calibration mode. The unit of measure will be displayed.
3. Press button **[3]**. The display will read "FILL".
4. Now dispense fluid into your container. "FILL" will blink on the display when flow is detected.
5. After dispensing fluid, press the ON button. The left digit of the display will blink. ("00.00")
6. Press button **[4]** to increment the digit to the amount of fluid dispensed (example: "05.00"). Press the **[ON]** button to move to the right. If you make a mistake, press button **[2]** to start back at the left-most digit.
7. After number is loaded, press the **[ON]** button again to accept the entered volume.
8. Display now shows the configured CAL factor.
9. Press the **[ON]** button again and the firmware version will be displayed.
10. Press the **[2]** button again to return to normal operating mode.

### NOTE

If the value entered is out of an acceptable range, the display will read "Err0" and the meter will revert to the previous settings. See Troubleshooting Guide for more information.

### TIP

If you are metering in ounces, pints, or quarts, it may be easier to switch the meter to a larger unit of measure such as gallons or liters for the calibration process and then change back to the desired unit of measure.

## Flush Mode (FLSH)

Use of Flush mode allows you to flush the meter without adding volume to the meter totals. This is useful when flushing the meter for storage or switching between different liquids and you want to maintain accurate totals.

1. Hold buttons **[3]** and **[4]** for 3 seconds. The Meter will display "FLSH".
2. Press button **[2]** to return to normal operating mode.

## Reset Accumulated Total

1. Press and hold buttons **[2]** and **[4]** for 3 seconds. The current firmware version will be displayed.
2. Press the **[ON]** button to display the accumulated total. If over 9999 units, the accumulated total will scroll across the display.
3. Hold buttons **[ON]** and **[4]** together for 5 seconds to reset the accumulated total.
4. Press the **[2]** button twice to return to normal operating mode.

## K-Factor Check

You can check the internal calibration factor for the meter. The displayed value is the number of sensor counts per selected unit of measure and CAL/Fluid factor. *The factory may ask you for this value if troubleshooting the Meter.*

1. Hold buttons **[3]** and **[4]** for 3 seconds. The Meter will display "FLSH".
2. Press and hold buttons **[ON]** and **[3]** together. The number of counts per unit of measure will be displayed.
3. Press button **[2]** to return to normal operating mode.

## Battery Replacement

Batteries should be replaced when the LOW battery icon begins to blink on the display. The meter totals, configuration, and calibration are preserved while the batteries are being replaced, so there is no need to recalibrate afterwards.



### WARNING!

When replacing batteries, make the area safe of explosive vapors, or move the meter electronics to a safe area before replacing them.

The batteries are accessed by removing the display as described in the section showing how to rotate the display.

The Battery Foam may be stuck to the batteries. Carefully remove it and reinstall at assembly. The Battery Foam protects the batteries and prevents them from becoming dislodged if the meter is handled roughly.

Pay attention to the polarity of the batteries as marked inside the battery holder. The meter will not operate if the batteries are installed incorrectly and damage may occur.

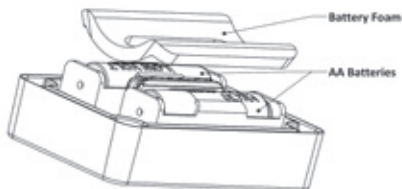

### **WARNING!**

To reduce the risk of explosion **DO NOT** mix old batteries with new batteries, or mix batteries of different manufacturers.

Batteries may **ONLY** be replaced with the following:

- Duracell MN1500
- Energizer E91
- Duracell QU1500

### **Maintenance and Storage**

If the meter will be stored for an extended period of time without use and is being used with a fluid that may leave a residue, it should be flushed with a compatible fluid to prevent sticking and binding of the turbine assembly.

The exterior of the meter may be wiped down with a mild water based detergent and damp cloth to clean the display. *Do not use a power washer to clean the meter.*

### **IMPORTANT!**

Use of compressed air **WILL** cause permanent damage to the meter. Always use a gentle stream of compatible fluid to rinse the interior of the meter.

### **Regulatory**

#### **Safety Testing Approvals**

The Fill-Rite TT10 Series meters have been tested for compliance to the standards set forth by Underwriters Laboratories (UL), UL Canada, ATEX, and other testing organizations. **To determine which specific compliances apply to your particular meter, refer to the faceplate for information and compliance logos.**

#### **FLOW METER FOR HAZARDOUS LOCATIONS Exia INTRINSICALLY SAFE (SECURITE INTRINSEQUE)**

Class I, Group D, T4; Class I, Zone 0, AEx ia IIA T4  
Ex ia IIA T4; IECEx UL 16.0147X; Ex ia IIA T4 Ga;  
-40°C < Ta < +60°C



#### **CE Certification Information**

**The TT10 Series meters bearing the CE mark have been certified to the following European directives:**

2011/65/EU: Restriction of the use of certain hazardous substances in electrical and electronic equipment. 2014/30/EU: Electromagnetic Compatibility

**The following standards were used to test and show compliance:**

#### **Emissions**

EN 55011:2009/A1:2010 Group 1, Class B, Industrial, Scientific, and Medical (ISM) Equipment

#### **Immunity**

IEC 61000-4-8: 2010 Magnetic Field

EN 60079-0: 2012 + A11:2013

IEC 60079 Edition 6

EN 60079-11: 2012

IEC 60079-11 Edition 6

UL60079-0 Sixth Edition

UL60079-11 Sixth Edition

CAN/CSA - C22.2 No 157-92



CAN/CSA - C22.2 No 60079-0:2014

CAN/CSA - C22.2 No 60079-11:2015

UL 25

ULC/ORD-C25

Table 2: Troubleshooting Guide

Problem	Possible Cause	Solution	
Meter won't turn on	<ul style="list-style-type: none"> <li>• Dead batteries</li> <li>• Damaged electronics</li> </ul>	<ul style="list-style-type: none"> <li>• Replace batteries</li> <li>• Replace the meter</li> </ul>	Seal to electronics is broken if the display is removed or punctured.
Flashing decimals	Counter has exceeded 9999 units	Reset display to zero by pressing and holding button 	Meter will continue to operate normally.
Flashing BAT Icon	Low batteries	Replace batteries	See battery replacement section
Leaking fluid at the inlet / outlet port	<ul style="list-style-type: none"> <li>• Need thread sealant</li> <li>• Cross-threaded port</li> </ul>	<ul style="list-style-type: none"> <li>• Add sealant to the joint</li> <li>• Replace the meter</li> </ul>	
Fluid flows; meter won't count	<ul style="list-style-type: none"> <li>• Turbine is jammed</li> <li>• Meter failure</li> </ul>	<ul style="list-style-type: none"> <li>• Flush the meter</li> <li>• Replace the meter</li> </ul>	
Meter reading is not correct	<ul style="list-style-type: none"> <li>• Air is in system</li> <li>• Meter is installed backwards</li> <li>• Fluid viscosity changed</li> <li>• Wrong CAL/fluid factor</li> <li>• Poor calibration</li> </ul>	<ul style="list-style-type: none"> <li>• Ensure meter is full of liquid at all times</li> <li>• Correct flow direction of the meter</li> <li>• Use correct CAL/factor</li> <li>• Recalibrate</li> </ul>	Meter will count air. Fluid viscosities will change with temperature
Meter is not consistent / repeatable	<ul style="list-style-type: none"> <li>• Air is in the system</li> <li>• Meter is installed backwards</li> <li>• Particulates in the fluid</li> <li>• Turbine is gummed up</li> <li>• Operating outside flow range of meter</li> </ul>	<ul style="list-style-type: none"> <li>• Ensure meter is full of liquid at all times</li> <li>• Correct flow direction of the meter</li> <li>• Flush the meter</li> <li>• Put a screen in front of meter</li> <li>• Operate within flow range of meter</li> </ul>	40 mesh minimum inlet screen
Err0	<ul style="list-style-type: none"> <li>• Calibration Error</li> <li>• Meter may have excessive wear</li> </ul>	<ul style="list-style-type: none"> <li>• Recalibrate with a more accurate container</li> <li>• Replace the meter</li> </ul>	Indicates fluid calibration is out of acceptable range. Volumetric container may not be accurate or there is air in the system. Meter may have excessive wear
Err1	Damaged electronics or Software error	<ul style="list-style-type: none"> <li>• Press and hold button  to reset counter and then recalibrate meter</li> <li>• Replace the meter</li> </ul>	
Err2	Bad eeprom	Replace the meter	Meter still functions but totals and calibration will be lost if batteries are removed.

## LIMITED WARRANTY POLICY

Revision Date: August 1, 2014  
Fill-Rite and Sotera Products

Tuthill Transfer Systems ("Manufacturer") warrants each consumer buyer of its products ("Buyer") from date of sale that goods of its manufacture ("Goods") shall be free from defects of materials and workmanship.

The duration of the warranty is as follows:

From Date of Sale	Not to Exceed the Following Period from Date of Manufacture	Product Series	
Five Years	60 Months	SP100 Series Pumps	400 Series Pumps
Two Years	27 Months	Heavy Duty Pumps and Meters, 820, 825, and 850 Meters	Cabinet Pumps, Cabinet Meters, TN Meters, TM Meters, TS Meters
One Year	15 Months	Standard Duty Pumps and Meters, 1600 Pumps	Accessories Parts

\* proof of purchase should be presented to place of purchase

\*\* see Appendix for definition of "Heavy Duty" and "Standard Duty" products

End users must contact the place where they purchased the product to process a warranty. "Place of purchase" is defined as any authorized TTS Distributor, including any and all retail stores, mail order houses, catalogue houses, on-line stores, commercial distributors.

Manufacturer's sole obligation under the foregoing warranties will be limited to either – at Manufacturer's option – replacing defective goods (subject to limitations hereinafter provided) or refunding the purchase price for such Goods theretofore paid by the buyer, and Buyers exclusive remedy for breach of any such warranties will be enforcement of such obligations of the Manufacturer. If the Manufacturer so requests the return of such Goods, the Goods will be redelivered to the manufacturer in accordance with Manufacturer's instructions FOB Factory.

The remedies contained herein shall constitute the sole recourse of the Buyer against the Manufacturer for breach of warranty. **IN NO EVENT SHALL THE MANUFACTURER'S LIABILITY FOR ANY CLAIM FOR DAMAGES ARISING OUT OF THE MANUFACTURE, SALE, DELIVERY, OR USE OF THE GOODS EXCEED THE PURCHASE PRICE.**

The foregoing warranties will not extend to goods subject to misuse, neglect, accident, improper installation or maintenance, or have been repaired by anyone other than the Manufacturer or its authorized representative. **THE FOREGOING WARRANTIES ARE EXCLUSIVE AND IN LIEU OF ALL OTHER WARRANTIES OF MERCHANTABILITY, FITNESS FOR PURPOSE OF ANY OTHER TYPE, WHETHER EXPRESSED OR IMPLIED.** No person may vary the forgoing warranties or remedies, except in writing signed by a duly authorized officer of the Manufacturer. The Buyer's acceptance of delivery of the Goods constitutes acceptance of the foregoing warranties and remedies, and all conditions and limitations thereof.



