



FILL-RITE®

The Most Trusted Name in Pumps and Meters

NX25-DDC SERIES DC FUEL TRANSFER PUMPS

Installation and Operation Manual

This manual contains English language only. Visit www.fillrite.com to download more languages.



Table of Contents

Unique nextec Features.....	3
Safety Information	3
Fueling Safety	4
Installation.....	4
Nozzle Boot Installation	5
Pump Foot Installation	5
Anti-Siphon Device	6
Tank Installation	6
DC Power Connection.....	7
Padlocking	7
Operational Safety	8
Operating Instructions	8
Dimensional Information	9
Technical Information	10
Accessories.....	10
Servicing the Bypass Valve.....	11
Replacement Parts Information	12
Servicing Rotor, Vanes and Shaft Seals	12
Exploded View.....	13
Troubleshooting.....	14
Intelligent Tones.....	15
Safety Testing Certifications	16

Thank You!

Thank you for your purchase of the Fill-Rite® NX25-DDC. Your Fill-Rite product comes with decades of pump manufacturing experience behind it, providing you the value that comes with superior performance, user friendly design, outstanding durability, and solid, simple engineering.

Tuthill Pump Your Heart Into It.



Limited Warranty Policy

Revision Date: August 1, 2014
Fill-Rite and Sotera Products

Tuthill Transfer Systems ("Manufacturer") warrants each consumer buyer of its products ("Buyer") from date of sale that goods of its manufacture ("Goods") shall be free from defects of materials and workmanship.

The duration of the warranty is as follows:

From Date of Sale	Not to Exceed the Following Period from Date of Manufacture	Product Series	
Five (5) Years	60 Months	400 Series Pumps	
Two (2) Years	27 Months	Heavy Duty Pumps and Meters, 820, 825, 850 Meters, and NX Series Pumps	Cabinet Pumps, Cabinet Meters, TN Meters, TM Meters, TS Meters
One (1) Year	15 Months	Standard Duty Pumps and Meters, 1600 Pumps	Accessories Parts

* Proof of purchase should be presented to place of purchase

End users must contact the place where they purchased the product to process a warranty. "Place of purchase" is defined as any authorized Tuthill Transfer Systems Distributor, including any and all retail stores, mail order houses, catalogue houses, on-line stores, commercial distributors.

Manufacturer's sole obligation under the foregoing warranties will be limited to either – at Manufacturer's option – replacing defective goods (subject to limitations hereinafter provided) or refunding the purchase price for such Goods theretofore paid by the buyer, and Buyers exclusive remedy for breach of any such warranties will be enforcement of such obligations of the Manufacturer. If the Manufacturer so requests the return of such Goods, the Goods will be redelivered to the manufacturer in accordance with Manufacturer's instructions FOB Factory.

The remedies contained herein shall constitute the sole recourse of the Buyer against the Manufacturer for breach of warranty. **IN NO EVENT SHALL THE MANUFACTURER'S LIABILITY FOR ANY CLAIM FOR DAMAGES ARISING OUT OF THE MANUFACTURE, SALE, DELIVERY, OR USE OF THE GOODS EXCEED THE PURCHASE PRICE.**

The foregoing warranties will not extend to goods subject to misuse, neglect, accident, improper installation or maintenance, or have been repaired by anyone other than the Manufacturer or its authorized representative. **THE FOREGOING WARRANTIES ARE EXCLUSIVE AND IN LIEU OF ALL OTHER WARRANTIES OF MERCHANTABILITY, FITNESS FOR PURPOSE OF ANY OTHER TYPE, WHETHER EXPRESSED OR IMPLIED.** No person may vary the foregoing warranties or remedies, except in writing signed by a duly authorized officer of the Manufacturer. The Buyer's acceptance of delivery of the Goods constitutes acceptance of the foregoing warranties and remedies, and all conditions and limitations thereof.

Unique Features of the nextec Pump

Your nextec fuel transfer pump will perform differently from non-intelligent pumps on start-up and while operating. You will want to keep the following in mind as you begin to use and learn how your nextec Intelligence™ pump operates.

- On initial start up, the pump may rev momentarily, but will slow down, as if idling, as it responds to the load it senses. This is a normal condition, and it will continue at this low speed until you squeeze the handle on the dispensing nozzle to begin fluid flow.
- When you squeeze the nozzle handle to begin flow, the microprocessor in the pump will sense the change, and will raise the RPM's to meet the load.

It is not uncommon for the pump to change RPM's during operation. It will do this as it senses performance parameters are changing; for example, if you increase or decrease the flow at the nozzle, the electronics controlling the motor will sense the changes and adjust the motor speed to optimize performance.

- If the pump senses a condition that is outside normal operating parameters (low battery voltage, for example), it will sound a series of tones to alert you to the condition, and to help you diagnose it. See the "Intelligent Tones" section of the Troubleshooting Guide on page 14 for greater detail on this feature.
- Your NX25-DDC pump has a Continuous Duty Cycle, meaning it does not have to be shut off to "rest" after a specific period of use. This allows you to move from fueling one piece of equipment to another without having to shut the pump off. The nextec Intelligence does, however, have an automatic shut off if the pump is left running in bypass mode (without dispensing any fluid) for 20 minutes. This feature protects from excessive battery drain, as well as excessive unnecessary wear to the pump in the event you forget to shut the pump off. Should the pump turn itself off under these conditions, simply cycle the power switch off, then back on to restore pump operation.
- The nextec Intelligence will also shut the motor down if:
 - ▶ Pump temperature exceeds threshold parameters
 - ▶ Supply voltage is outside threshold parameters
 - ▶ Rotor is locked





About This Manual

From initial concept and design through its final production, your Fill-Rite pump is built to give you years of trouble-free use. To ensure it provides that service, and to avoid injury or death, it is critical that you read this entire manual prior to attempting to install or operate your new pump. Become familiar with the terms and diagrams, and pay close attention to the highlighted areas with the following labels:

	DANGER! Emphasizes an area in which personal injury or even death will result from failure to follow instructions properly. Mechanical damage may also occur.		WARNING! Emphasizes an area in which personal injury or even death may result from failure to follow instructions properly. Mechanical damage may also occur.
	CAUTION! Failure to observe a "Caution" may cause damage to the equipment.		IMPORTANT! These boxes contain information that illustrates a point that may save time, or be key to proper operation, or clarifies a step.

At Tuthill, your satisfaction with our products is paramount to us. If you have questions or need assistance with your product, please contact us at 1-800-634-2695 (M-F 8 AM–6 PM ET).

Safety Information

	DANGER! Electrical wiring should be performed with extreme caution and in compliance with local, state, and national electrical code NEC/ANSI/NFPA 70, NFPA 30, and NFPA 30A, as appropriate for the intended use of the pump. Threaded rigid conduit, sealed fittings, and conductor seal should be used where applicable. The pump must be properly grounded. If installing in deviation of this manual, a licensed electrician must perform the installation. Improper installation or use of this product will result in serious bodily injury or death!
	DANGER! To ensure safe and proper operation of your equipment, it is critical to read and adhere to all of the following safety warnings and precautions. Failure to follow instructions below, improper installation, or use of this product, will cause serious bodily injury or death! <ul style="list-style-type: none"> • NEVER smoke near the pump, or use the pump near open flames when pumping a flammable liquid! Fire can result! • This product shall not be used to transfer fluids into any type of aircraft.
	DANGER! To minimize static electricity build up and possible explosion, use only static wire conductive hose when pumping flammable fluids, and keep the fill nozzle in contact with the container being filled during the filling process. Spark / static discharge will cause explosions.
	WARNING! Threaded pipe joints and connections should be sealed with the appropriate sealant or sealant tape to minimize the possibility of leaks. Leaking fuel may cause the potential for fire and explosion.
	CAUTION! The pump motor is equipped with electronic protection from thermal overload; if overheated, the motor will shut off. After the motor has cooled, you may cycle power or the switch to reset this safety feature and continue use. The pump will not restart until properly cooled.



CAUTION! This product is not suited for use with fluids intended for human consumption or fluids containing water. Materials of construction are not food grade. Water will cause rust and corrosion in the pump housing. If water enters the pump, flush immediately with a petroleum product (gasoline, diesel, light oil, etc) to eradicate residual water.



IMPORTANT! A Fill-Rite filter should be used on the pump outlet to ensure no foreign material is transferred to the fuel tank. Foreign material can damage the equipment being fueled.

Fueling Safety



DANGER! Fumes accumulated while fueling create an Explosive Atmosphere. It is **CRITICAL** that all possible sources of ignition be removed to a safe distance or extinguished. Sources of ignition would include (but not be limited to) open flames, cigarettes, static discharge, or electrical connections that can create a spark. Explosion, fire, and severe injury or death will occur if the explosive vapors are ignited.

As a tank is being filled, air is displaced and exits via the fuel tank vent creating fumes, which when accumulated create an Explosive Atmosphere. To avoid possible explosion of accumulated vapors, it is critical to keep possible sources of spark / ignition at safe distances from the fuel vapors.

The accompanying diagram shows minimum safe distances for safe fueling. 10' is the minimum safe distance between:

- Power source and fuel supply
- Power source and tank being filled
- Power source and pump

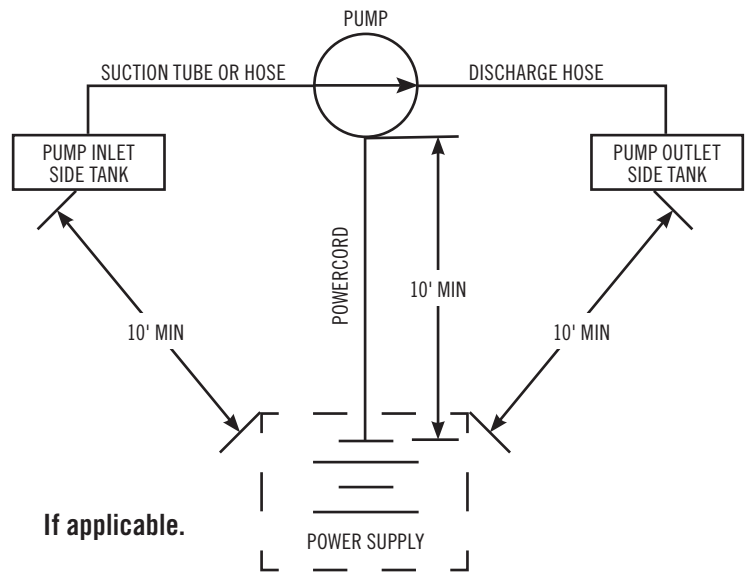

<p>WARNING</p> <ul style="list-style-type: none"> • STATIC ELECTRIC SPARK EXPLOSION HAZARD. • NEVER fill portable containers that are in or on vehicles. 		<ul style="list-style-type: none"> • ALWAYS PLACE CONTAINERS ON GROUND. • Keep nozzle in contact with container while filling. 		<p>A static electric spark can occur when filling portable containers sitting on truck bed liners, or on any vehicle's carpeting or floor matting.</p> <p>This spark will explosively ignite a gasoline vapor fire and cause SERIOUS INJURY or DEATH.</p>
---	--	--	--	---

Installation

Your Fill-Rite NX25-DDC pump is designed to be mobile for your convenience and safety. It can be installed / used in several configurations. Read each configuration prior to beginning installation.



WARNING! The NX25-DDC smart pump is designed for use on skid tanks, and large bulk tanks to supply fuel. It is paramount to anchor the supply tank to which the pump is mounted to ensure no movement occurs in transit or while fueling. Failure to secure the tank or drum can cause unexpected and uncontrolled movement, resulting in damage, injury, death, and potential fire or explosion.



IMPORTANT! Do not use check valves or foot valves; valves reduce rate of flow and performance of the pump.

Nozzle Boot Installation

Install the nozzle boot using the supplied attaching bolt. Note that the bolt is inserted through the hole closest to the nozzle opening, and the boot is then positioned so the peg on the pump mounting surface inserts in the top second hole of the boot.

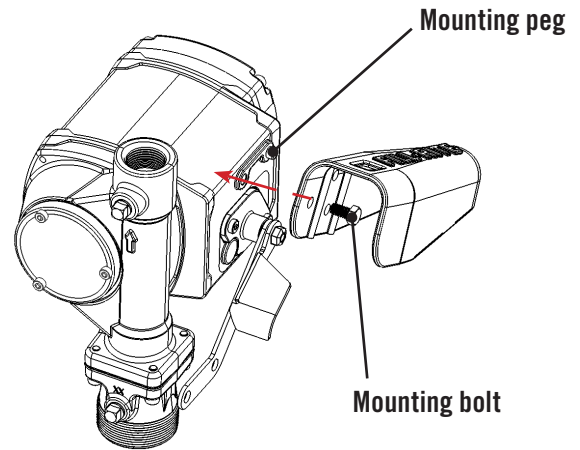

Pump Foot Installation

The mounting foot is bolted to the bottom of the pump using the four supplied socket head cap screws. Mount the foot with the bolt flanges inboard of the mounts on the pump as illustrated. Torque to 50 in lb. with 4 mm hex key.

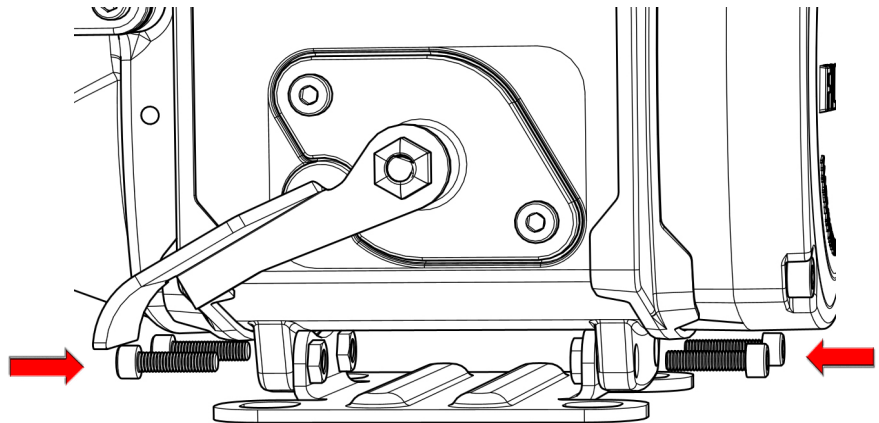

Anti-Siphon Device

NX25-DDC pumps come from the factory ready to install an anti-siphon tube back to the tank. An anti-siphon device (a.k.a. vacuum breaker) is important because it will break a liquid siphon if there is an open nozzle or a leaking hose below the fluid level in the tank when the pump is turned off. Fill-Rite recommends anti-siphon kit # KIT321ASN be installed from the pump outlet back to the vapor space in the tank.

This illustration shows where to install the tube so that it terminates in the vapor space at the top of the tank. The tube must terminate in the vapor space; if it terminates below the fluid level in the tank, it will not prevent siphoning. It is very important there are no liquid traps in the tubing; it must have a continuous slope from the pump down to the tank, and can be connected into any opening in the top of the tank if the tank adapter is not used. Use reducer bushings as required for proper fit and seal.

The 1/4 NPT opening in the side of the tank adapter terminates in the vapor space of the tank. Make liquid-tight connections using the appropriate sealant from the adapter to the anti-siphon outlet using a minimum of 1/4 metal tubing that is compatible with whatever liquid is being pumped. If the anti-siphon tank adapter is being used and the 1/4 NPT opening is not used for the tubing, leave the factory installed plug in place.

Fill-Rite offers Anti-Siphon kit # KIT321ASN (available through your Fill-Rite distributor). This kit contains the necessary fittings and tubing to complete the installation as pictured in this section. NOTE: This kit ONLY works for tank top installations.

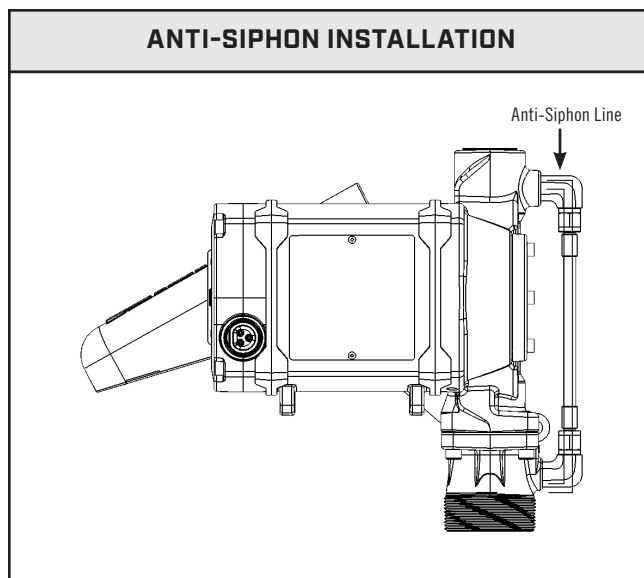

Tank Installation

The NX25-DDC pump mounts to the bung of a tank by way of the tank adapter that is bolted to the inlet flange. The suction tube threads into the bottom of the tank adapter, and must be cut to a length that positions it at least 3" from the bottom of the tank. The tank must be equipped with a vent cap.

Materials:

- 1-1/4" steel pipe cut to a length at least 3" above of the bottom of the tank when screwed into the tank adapter, with the tank adapter screwed into the bung connection on top of the tank.
- Thread pipe joint sealant appropriate for the application.

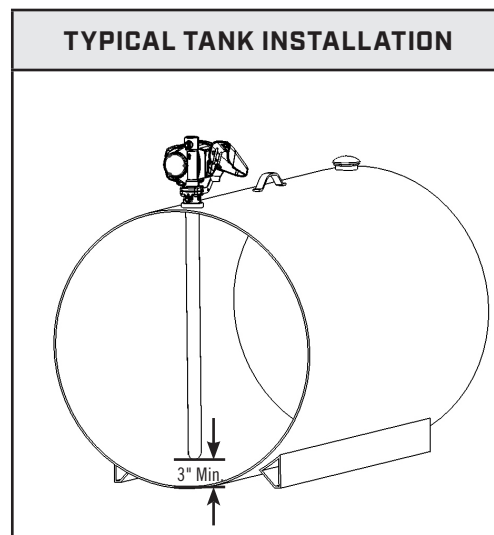
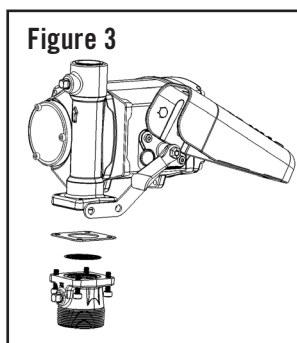
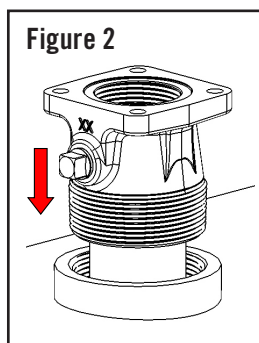
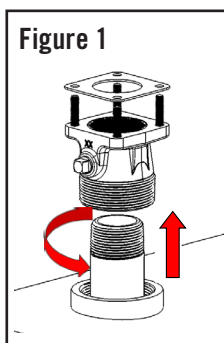

1. Thread the 1-1/4" pipe into the tank adapter. Seal threads liquid tight with appropriate sealant (Figure 1).
2. Screw the tank adapter (with suction pipe) into the tank bung; seal threads liquid tight with appropriate thread sealant (Figure 2).
3. Mount the pump on the adapter; making sure the seal and screen are installed as shown (Figure 3).



IMPORTANT! Be certain the screen is properly seated in the indentation in the tank adapter before installing seal and tank adapter to the pump. Failure to properly seat the screen can result in fluid leakage.

DC Power Connection



DANGER! Be certain the switch is “OFF” prior to connecting the power cables to the power source or installing the cable into the pump to prevent unexpected starting of the motor. Unexpected motor start can cause unintended discharge of fuel, creating an explosion and fire hazard. Note that the switch does not interrupt power to the motor; it triggers a relay that tells the motor to turn on.



WARNING! BE CERTAIN the power cables are connected to the correct terminals at your power source. **REVERSING POLARITY WILL DAMAGE THE PUMP** and void the warranty.



CAUTION! Do not remove the fuse on the red (positive) wire. Removing the fuse **MAY DAMAGE THE PUMP** and will void the warranty.

Inspect power cable before each use! Damage to the outer jacket of the cable that exposes wiring requires replacement of the power cable.

1. The green (ground) wire should be connected first. Connect the green wire to the vehicle chassis or earth ground. **DO NOT** connect the green wire to the negative power source post.
2. Next, connect the black (negative) wire to the negative post of the DC power source.
3. Connect the red (positive) wire to the positive post last.

Install power cable by aligning flat on plug with back of pump. Insert the plug into the motor housing as shown. Lock into place using the threaded collar (A). **HAND TIGHTEN ONLY!**

Disconnect in reverse order.

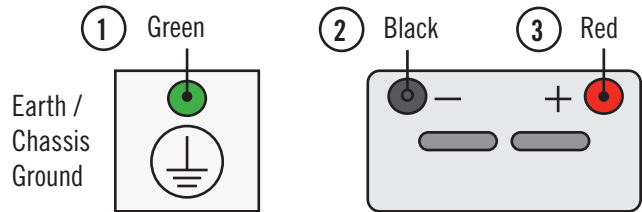
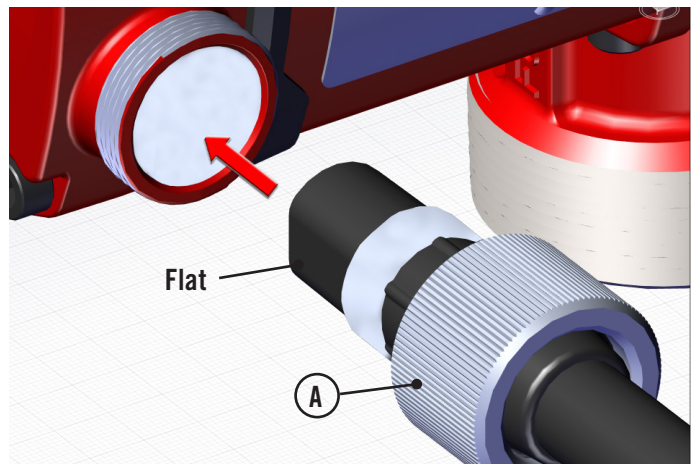

Padlocking

Your Fill-Rite pump nozzle can be padlocked to the pump for added security. With the pump turned off, and the nozzle in the stored position, a padlock can be inserted through the locking link and the nozzle handle opening. This configuration prevents the nozzle from being removed from the nozzle boot.

The locking link is located on the nozzle side of the pump, and can be pivoted into position to work with a variety of nozzles.

Use the appropriate position and hole to lock your nozzle securely to your NX25-DDC pump.

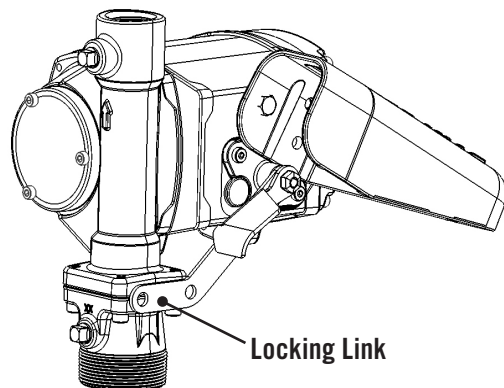

Operational Safety



DANGER! DO NOT use pump in enclosed areas when pumping hazardous or explosive fluids. Pumping area should be well ventilated. Concentrated vapors in an enclosed area are noxious and highly explosive!



WARNING! NEVER disconnect the power cable from the pump while pump is switched on or connected to a power source. **ALWAYS** switch the pump off and disconnect all the clamps from the power source **PRIOR** to disconnecting the power cable from the pump. Electrical shorts, sparks, or unexpected start up can occur.



WARNING! Use caution when operating the pump. The hoses and electrical power cable can be a trip hazard; caution should be exercised while moving around the hoses and power cable connected to avoid tripping or entanglement.



WARNING! Pump assembly can become hot with extended use. Use caution if you have to touch the pump after extended periods of use.



CAUTION! Always keep the nozzle in contact with the container being filled during the filling process to minimize the possibility of static electricity build up.

Operating Instructions



CAUTION! Always keep the nozzle in contact with the container being filled during the filling process to minimize the possibility of static electricity build up.

1. If so equipped, reset Meter to "0" (do not reset while in use as this can cause damage to the meter).
2. Remove dispensing nozzle from nozzle boot.
3. Move the switch lever to the "ON" (raised) position to start the motor (Figure 5). The pump should start and settle into a slow idle.
4. Insert the dispensing nozzle into the container to be filled.
5. Operate the nozzle to dispense fluid; release nozzle when the desired amount of fluid has been dispensed.
6. Move switch lever to the "OFF" (lowered) position (Figure 6) to stop the motor.
7. Remove the dispensing nozzle from the container being filled and store it in the nozzle boot.

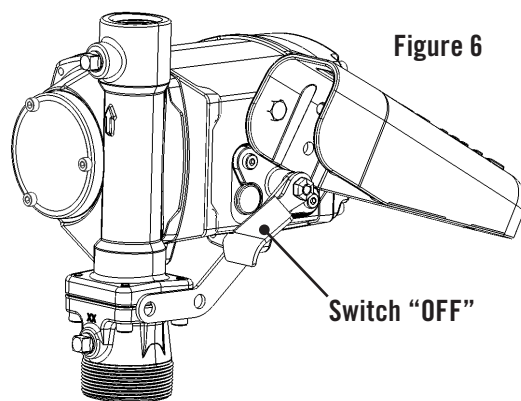
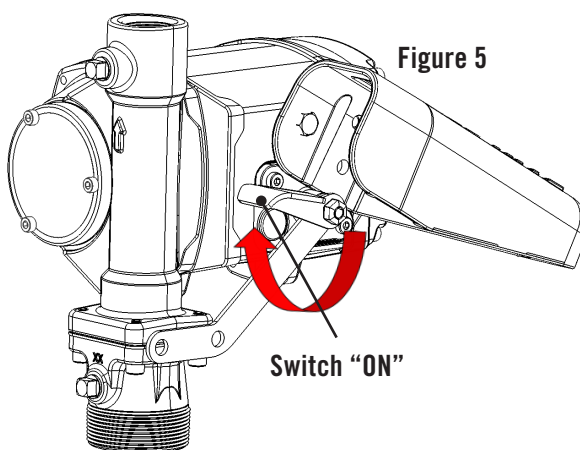

IMPORTANT! The motor has power at all times when connected to a power source. The switch does not apply or interrupt power to the motor. High voltage may still be present inside the pump after power is removed.

NX25-DDC Dimensional Information

All measurements are in inches [millimeters].

Bung Mount Dimensional Information

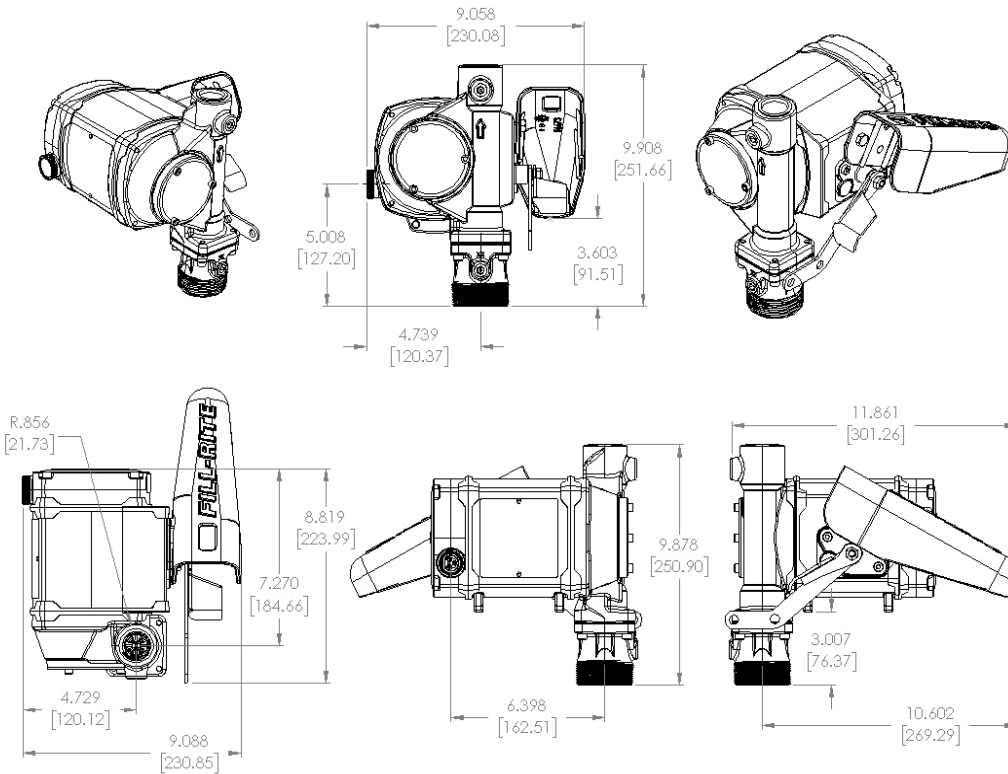

Foot Mount Dimensional Information

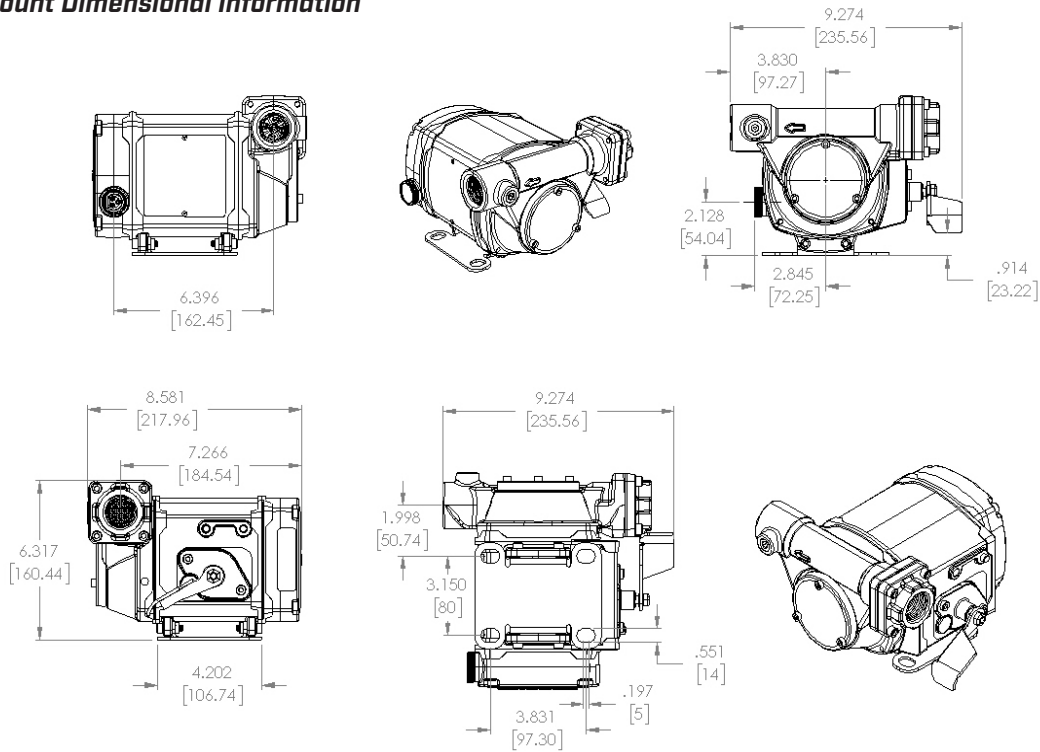

Technical Information

Motor	Specification
Power - DC 12, 24, 12/24	12 - 24 VDC
HP (horsepower) rating	1/3 HP
Power cable length	20'
Power cable gauge	10 AWG
Power cable DC battery connectors	Yes
Amps (MAX)	30 - 15 Amp
RPM	Variable 400 - 3500
Duty cycle	Continuous
Thermal protection	Electronically Protected
Circuit protection fuse	Yes (35 Amp Fuse)
Certification	UL/cUL listed/CE/ATEX/IECEX/EAC
Pump	
Design	Positive Displacement Rotary Vane
Flow rate (with supplied hose / nozzle)	Up to 25 GPM / 95 LPM
Flow rate open flow - no hose or nozzle	Up to 28 GPM / 106 LPM
Max discharge pressure	21 PSI
Dry vac (in Hg)	11 in vacuum
Head – Max (ft)	48'
Anti-siphon valve	None
Inlet – size / thread	1-1/4" NPT / BSPP
Outlet – size / thread	1" NPT / BSPP
Mount	2" Bung NPT or BSPT
Materials of construction – pump housing	Cast Iron
Materials of construction – wetted material	BUNA-N + Fluorocarbon
Rotor materials of construction	Powdered Iron
Rotor vane material of construction	Acetal
Compatible fluids	Diesel, Gasoline, BioDiesel up to B20, E15, Kerosene, Mineral Spirits, Methanol (up to 15%)
Strainer mesh size	20 x 20
Warranty (yr)	2 Year
Maximum sound level	75.3 dB

Accessories

Accessories	Description
N100DAU13	1" Ultra Hi Flow Automatic Nozzle
N100DAU12G	1" Hi-Flow Automatic Nozzle (Diesel)
N100DAU13G	1" Ultra Hi-Flow Automatic Nozzle (Diesel)
N100DAU12	1" Hi Flow Automatic Nozzle
900CD	Digital Meter
900CDP	Digital Meter with Pulser
FRH10020	20' x 1" Static Discharge Hose
FRH10012	12' x 1" Static Discharge Hose
S100H1315	1" Multi Plane Swivel
TT10AN	1" Digital In-Line Turbine Meter
700ACCF7017	1" Filter Head
F4010PM0	10 Micron Filter
F4030PM0	30 Miron Filter

Servicing the Bypass Valve (Dis-assembly)



WARNING! Disconnect electrical power and relieve any pressure in the lines prior to servicing this pump! Failure to do so can result in damage to the equipment and personal injury or death!



IMPORTANT! Removal of the bypass valve in the NX25-DDC pump requires special attention; please adhere to the replacement procedure in the kit instructions to minimize the possibility of damaging the pump housing during the removal and reinstallation process. Kit instructions accompany all purchased kits.

The bypass valve is located inside the pump housing. It is accessed through the inlet and outlet openings.

It consists of three main components (Figure 1):

- A. Bypass Valve Retainer
- B. Bypass Valve Spring
- C. Bypass Valve

1. Unbolt the pump from the tank adapter.
2. Using a blunt object approximately 4" long (i.e. a deep well socket on an extension) inserted in the inlet opening, push the bypass valve firmly in place against the seat it seals on (Figure 2).
3. While holding the bypass valve firmly in place with the socket, insert needle nose pliers (at least 4" long) into the outlet opening and grasp the bypass valve retainer (Figure 2 & 3).
4. Push the bypass valve retainer down slightly and rotate it 90 degrees counter-clockwise. This will align the slot in the retainer with the key on the valve, allowing you to remove the retainer (Figure 2 & 3).

Servicing the Bypass Valve (Re-assembly)



WARNING! Always wear eye protection anytime you look into the Pump Outlet; a miss-positioned or improperly installed valve spring retainer can pop up unexpectedly. Note that use of a small flashlight will help you better see and more easily align the components in this task.

1. Using needle nose pliers, place the bypass valve retainer on top of the bypass valve spring. Carefully align the slot in the top of the bypass valve retainer with the locking tab on top of the bypass valve (Figure 4).
2. Push the bypass valve retainer down over the locking tab on the bypass valve. Push the retainer down (compressing the spring) until it is completely below the locking tab (Figure 5).
3. Rotate the bypass valve retainer 90 degrees counter-clockwise and allow the spring to gently push it back up to contact the locking tab. The locking tab **MUST** be seated in the indentation in the bypass valve retainer (Figure 6).



WARNING! It is critical that the locking tab be seated in the indentation in the bypass valve retainer as illustrated. Failure to do so can cause the Retainer to come off when operating in bypass mode, potentially damaging the pump, or ejecting upward through the pump outlet while servicing.

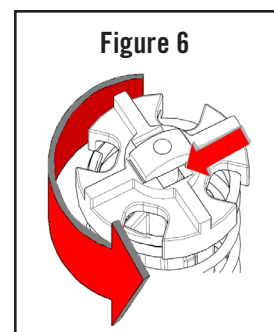
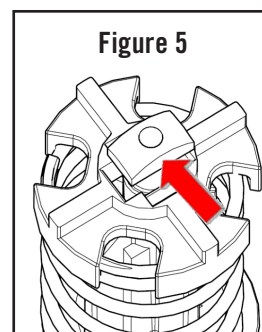
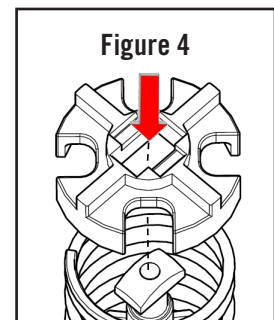
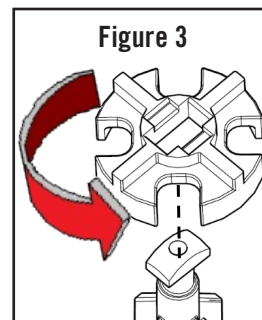
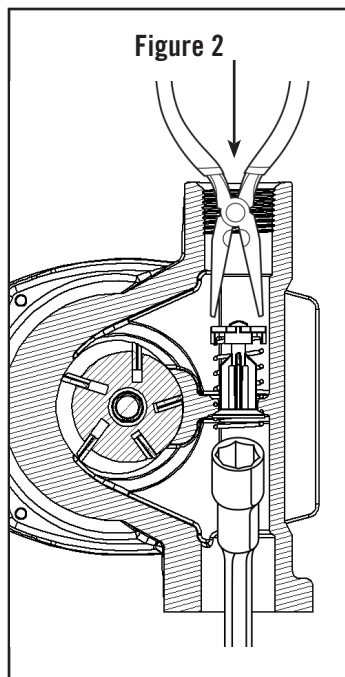
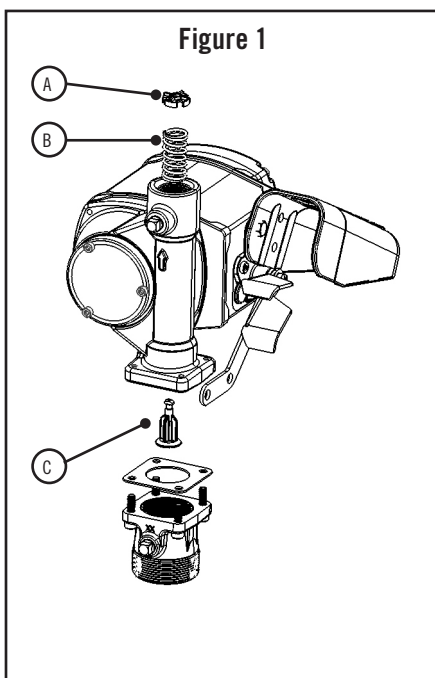

Replacement Parts Information

For repairs or routine maintenance, Fill-Rite offers the parts you need. The following parts diagram and list covers all applicable parts for your Fill-Rite product. These parts can be obtained through any authorized Fill-Rite dealer. Be sure to use only genuine Fill-Rite replacement parts for your service and maintenance needs. For a list of authorized dealers, please visit our web site at “www.fillrite.com”.



WARNING! DO NOT open or attempt to repair the motor on your NX25-DDC pump. Opening the motor case can compromise the integrity of the Explosion Proof construction and will void any existing warranty and certification (UL listing). *Please refer to the warranty policy located on page 2.*

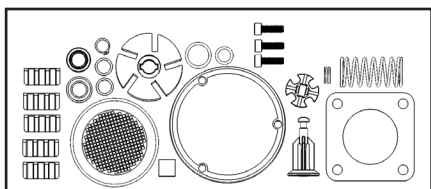

KIT321RK - Overhaul repair kit

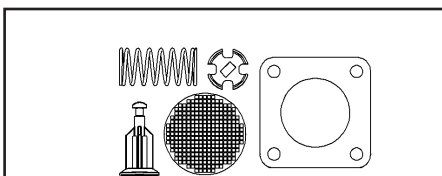

KIT321BV - Bypass kit

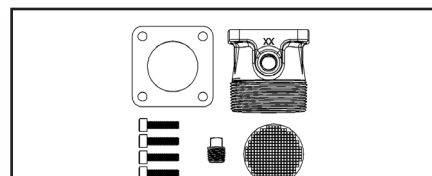

KIT321BG - Inlet kit

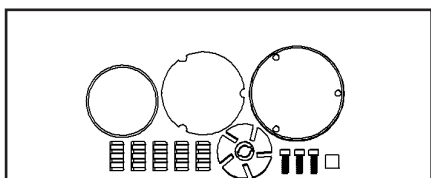

KIT321RG - Rotor kit

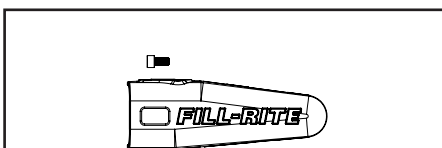

KIT321NB - Nozzle boot kit

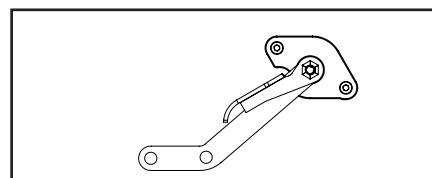

KIT321SW - Switch kit

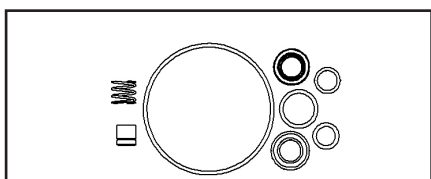

KIT320SL - Shaft seal kit

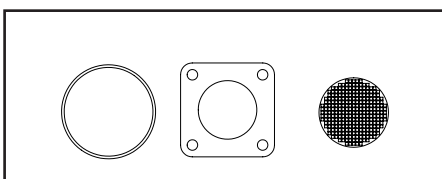

KIT321SK - External seal kit

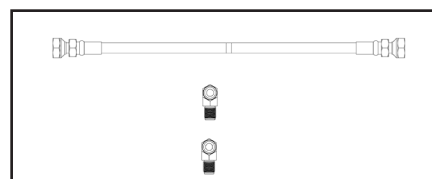

KIT321ASN - Anti-siphon kit

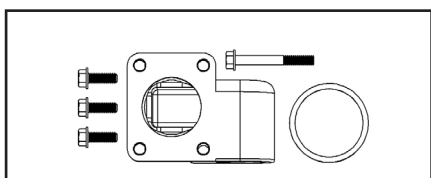

KIT321FLG - Flange kit

Servicing Rotor, Vanes, and Shaft Seals

The rotor, vanes, and shaft seals are inside the pump housing, and are accessed through the rotor cover located on the face of the pump. It is held in place with three 4mm hex drive attaching bolts. You can access the rotor and vanes for inspection and cleaning, but **DO NOT** attempt to remove the shaft seals without a new seal kit to install.

Always inspect the rotor cover seal and mating surface (groove) for nicks or damage prior to reassembly. Be certain o-ring is not pinched to prevent leakage. Torque the attaching hardware to 44 in-lbs.

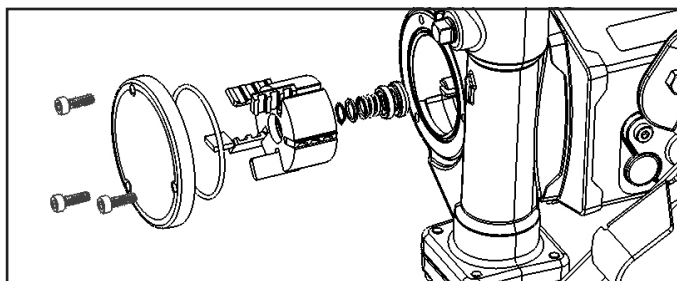

NX25-DDC Exploded View

Bung Mount Configuration

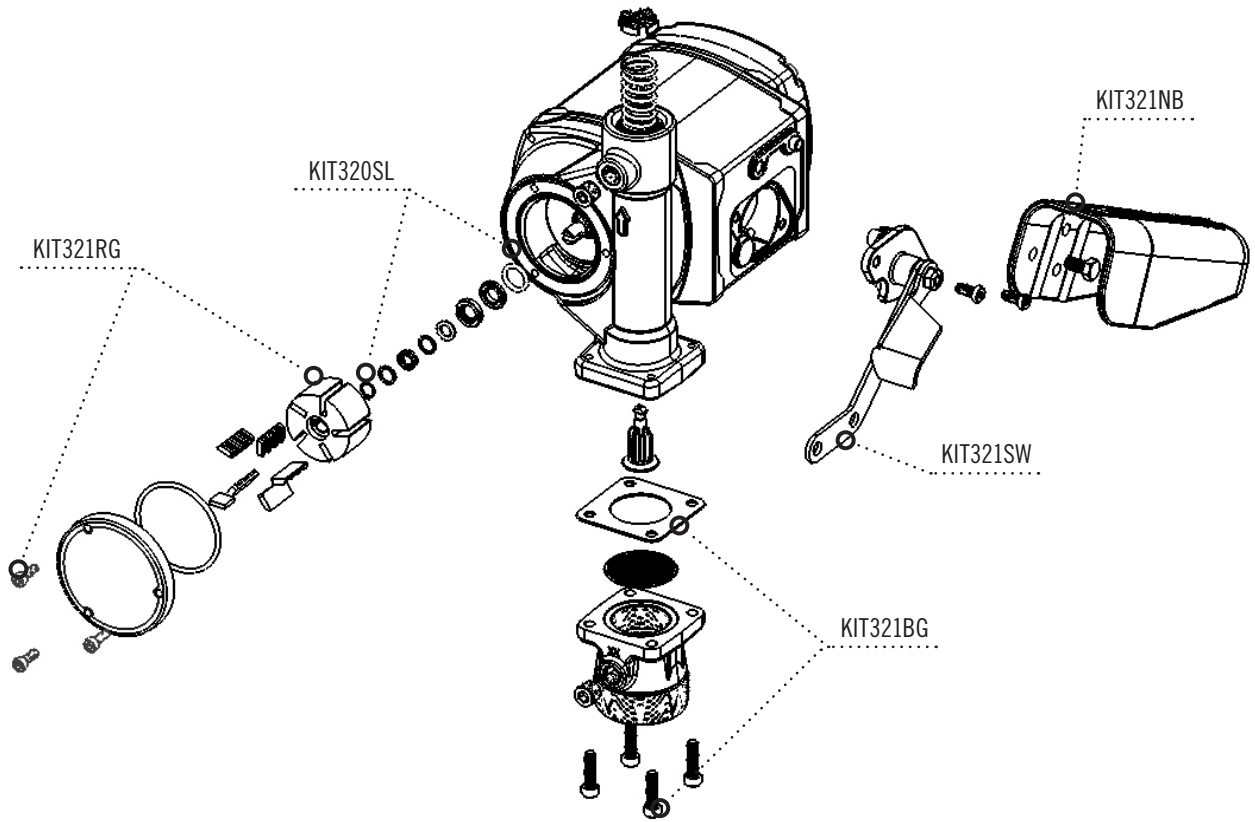

Foot Mount Configuration

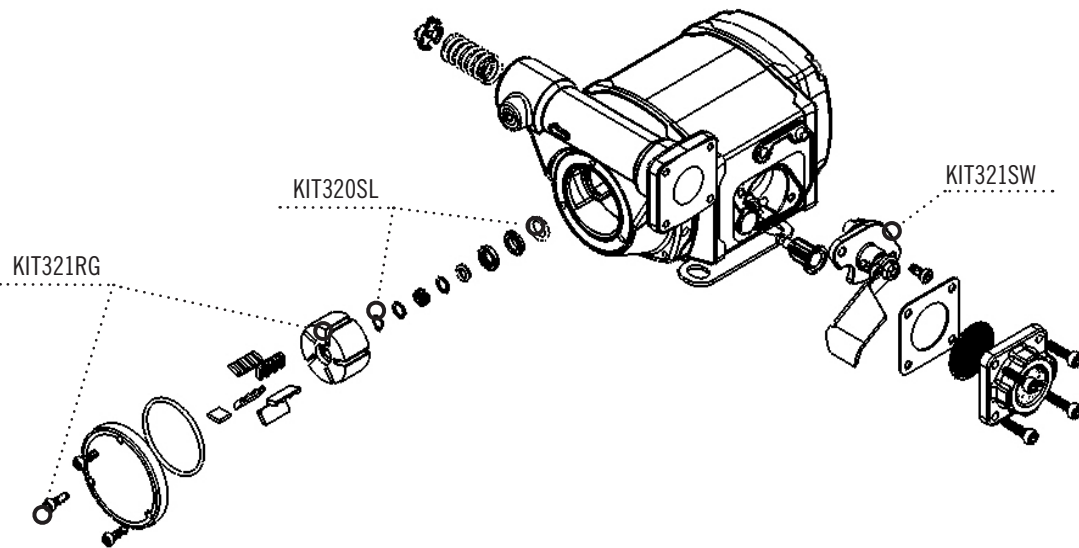

Troubleshooting



DANGER! Disconnect all power prior to performing any service or maintenance. Failure to disconnect the power may cause electrical shock, or unexpected starting of the motor, resulting in injury or death.



WARNING! DO NOT open or attempt to repair the motor on your NX25-DDC series pump. Opening the motor case can compromise the integrity of the Explosion Proof construction and will void any existing warranty and certification (UL listing). **Please refer to the warranty policy located on page 2.**

This Troubleshooting guide provides basic diagnostic assistance. If you have further questions, contact us at 1-800-634-2695 (M-F 8 AM–6 PM ET), or on the web at “www.fillrite.com”.

Symptom	Cause	Solution
Pump won't prime	1. Suction line problem	Check suction line for leaks or restrictions; it may be too small in diameter, too long, or not air tight
	2. Vanes sticking	Check vanes for nicks, damage, obstructions, or excess wear; replace as necessary
	3. Excessive rotor, vane, rotor cover, or housing wear	Inspect rotor, vanes, rotor cover, and housing for excess wear; replace as necessary
	4. Inlet / Outlet blocked	Check pump, hose, nozzle, and filter / strainer for blockage
	5. Excessive vertical or horizontal inlet plumbing	Reduce vertical or horizontal distance from pump to liquid
	6. Bypass valve stuck	Open valve, remove debris
Low capacity	1. Excessive dirt in screen	Remove and clean screen
	2. Suction line problem	Check suction line for leaks or restrictions; it may be too small in diameter, too long, not air tight, or too low vertically
	3. Excessive rotor, vane, rotor cover, or housing wear	Inspect rotor, vanes, rotor cover, and housing for excess wear; replace as necessary
	4. Hose or nozzle damage	Replace hose or nozzle
	5. Low fluid level	Refill tank
	6. Clogged outlet filter	Replace filter
Pump runs slowly	1. Pump in bypass	Normal operation; pump naturally reduces speed in bypass mode
	2. Vanes sticking	Check vanes for nicks, damage, obstructions, or excess wear; replace as necessary
	3. Motor problem*	Refer to warranty policy
	4. Excessive outlet restrictions	Reduce outlet restrictions (e.g. use shorter hose, remove swivel)
Motor stalls / breaker trips	1. Short in wiring	Inspect electrical wiring for shorts and replace as necessary
	2. Excess rotor or vane wear	Check vanes for nicks, damage, obstructions, or excess wear; replace as necessary
	3. Pump rotor lock-up*	Clean and inspect rotor and vanes; replace as necessary
	4. Debris in pump cavity	Clean debris from pump cavity

Bold text indicates repairs that are not serviceable by the owner; **please refer to our warranty policy on page 2 for further instructions.**

*This condition will shut the motor off.

Troubleshooting



DANGER! Disconnect all power prior to performing any service or maintenance. Failure to disconnect the power may cause electrical shock, or unexpected starting of the motor, resulting in injury or death.



DANGER! DO NOT open or attempt to repair the motor on your Tuthill pump. Return it to the place of purchase for service. Opening the motor case will compromise the integrity of the Explosion Proof construction and void any existing warranty, approvals, and certifications (i.e.: ATEX, UL listing, CE, etc.).

This Troubleshooting guide provides basic diagnostic assistance. If you have further questions, contact us at 1-800-634-2695 (M-F 8 AM–5 PM ET), or on the web at “www.fillrite.com”.

Intelligent Tones

Your NX25-DDC pump features a self-diagnostic system that will aid you in troubleshooting should the need arise. The pump will give off a series of high and low tones; simply count the high and low tones to determine which conditions exist.

Depending on the condition the pump senses, it will generate either a **3-tone code**, or a **4-tone code**:

- **3-Tone codes** indicate an application fault; something dealing with the installation of the pump, like a priming or supply voltage concern.
- **4-Tone codes** indicate a pump fault; a condition outside the operating parameters of the pump, like an over- temperature condition, or something dealing with the pumps internal electronics.

Refer to the table below to determine which condition your pump is detecting, and how to resolve it. In the chart below, arrows pointing up (↑) indicate high tones, arrows pointing down (↓) indicate low tones; their order tells which fault is detected. Conditions listed in **BOLD** are not field servicable, and require the pump to be returned to the manufacturer.

3-Tone Faults (Application / Installation faults)

Tones	Condition	Cure
↑ ↓ ↓	Low battery voltage (auto shut-off)	Charge or replace battery*
↑ ↓ ↑	High battery voltage (auto-shut off)	Connect to 12 to 24 VDC power source*
↓ ↑ ↑	Locked rotor (auto shut-off)	Turn switch off and inspect rotor and vanes*
↓ ↑ ↓	Priming / Suction / Lift failure	Check for leaks in suction tube, inlet connections, inside tank plumbing restrictions, excessive vertical suction lift, empty tank

4-Tone Faults (Hardware faults)

Tones	Condition	Cure
↓ ↑ ↑ ↑	Hardware fault (auto shut-off)	Troubleshoot as described below**
↓ ↑ ↓ ↓	Hardware overtemperature (auto-shut off)	Turn switch off and allow pump to cool*
↓ ↓ ↑ ↑	Motor overtemperature (auto shut-off)	Turn switch off and allow pump to cool*
↓ ↓ ↑ ↓	Motor overvoltage (auto shut-off)	Troubleshoot as described below**
↓ ↓ ↓ ↑	Motor undervoltage (auto shut-off)	Troubleshoot as described below**

*This condition will shut the motor off. To restart the motor, cycle the switch off, then back on.

** **Prior to returning pump to place of purchase, perform this procedure:** cycle the switch off and disconnect power for at least one minute. Reconnect power, and cycle the switch back on. Verify proper pump operation. If this procedure does not restart the pump, or if you have additional questions, contact Customer Service at 1-800-634-2695.

Safety Testing Certifications

This Fill-Rite line of pumps have been safety tested for compliance to strict regulatory standards. Check the information on the motor barrel label of your pump to determine the certifications that are applicable to your particular model.

The following standards were used to show compliance in North America:

UL 674 – Electric Motors and Generators for Use in Hazardous (Classified) Locations, 5th Edition.

The following standards were used to show compliance in the European Union:

Directive 2006/42/EC – Directive on machinery.

EN 809:1998 +A:2009 – Pumps and pump units for liquids – Common safety requirements.

EN ISO 12100:2010 – Safety of Machinery – Basic concepts, general principles for design.

Directive 2004/108/EC – Electromagnetic compatibility.

Directive 2011/65/EU – Restrictions of the use of certain hazardous substances in electrical and electronic equipment.

ISO 80079-36 = Explosive atmospheres - Part 36: Non-electrical equipment for explosive atmospheres - Basic method and requirements.

ISO 80079-37 = Explosive atmospheres - Part 37: Non-electrical equipment for explosive atmospheres - Non-electrical type of protection constructional safety “c”, control over ignition source “b”, liquid immersion “k”.

EN 60079-0:2012+A11:2013 – Explosive atmospheres – Part 0: Equipment – General requirements.

EN 60079-1:2014 – Explosive atmospheres – Part 1: Equipment protection by flameproof enclosures “d”.

IEC 60079-0 – Explosive atmospheres – Part 0: Equipment – General requirements.

IEC 60079-1 – Explosive atmospheres – Part 1: Equipment protection by flameproof enclosures “d”.

The fasteners used to assemble the flame-proof enclosure are of a property class (grade) 12.9.

Manufacturer is to be contacted for information on the dimensions of the flameproof joints.



Tuthill Corporation | 8825 Aviation Drive Fort Wayne, Indiana 46809

P (800) 634-2695 | (260) 747-7524 | F (800) 866-4681

www.tuthill.com | www.fillrite.com | www.sotera.com

