

PIUSIBOX CAR SUCTION

FEATURES

- IDEAL TO EMPTY VEHICLE TANKS
- IT AVOIDS THE TANK OVERFILLING
- SUZZARABLUE DIAPHRAGM PUMP
- EASY TO HANDLE

The PIUSI BOX CAR SUCTION is the perfect solution for those who need to drain an AdBlue® vehicle tank before servicing. It comes with a portable box that contains all the required equipment.

PERFORMANCE

UP TO 34 L/MIN FLOW RATE	AC VOLTAGE POWER
MAX 2M BOUND HOSE LENGTH	



PIUSIBOX CAR SUCTION



PACKAGING

CODE	WEIGHT		PACKAGING		
	KG	LBS	MM	INCH	PCS/BOX
FOO201R20	11,5	25,3	650X400X450	25,6X15,7X17,7	1

FUNCTIONING

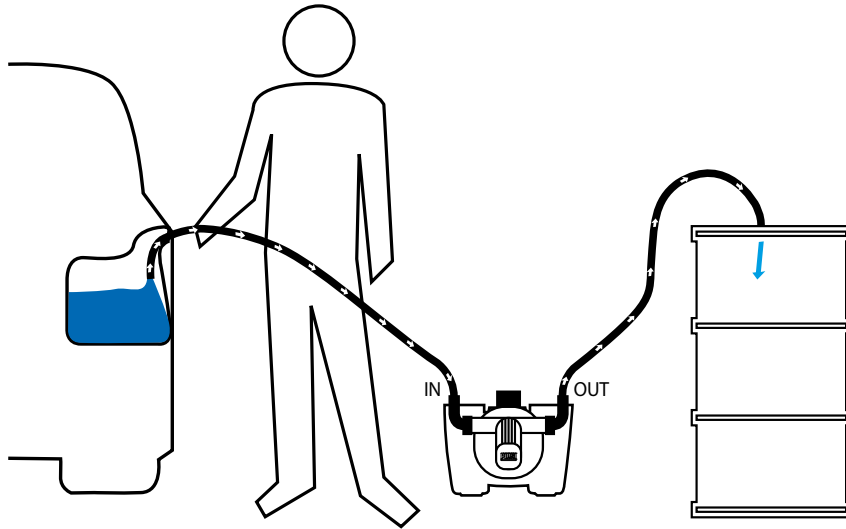

IN THE BOX

- SUZZARABLU PUMP
- SUCTION/DELIVERY HOSE
- INSTRUCTION MANUAL

DETAILS



DIMENSIONS

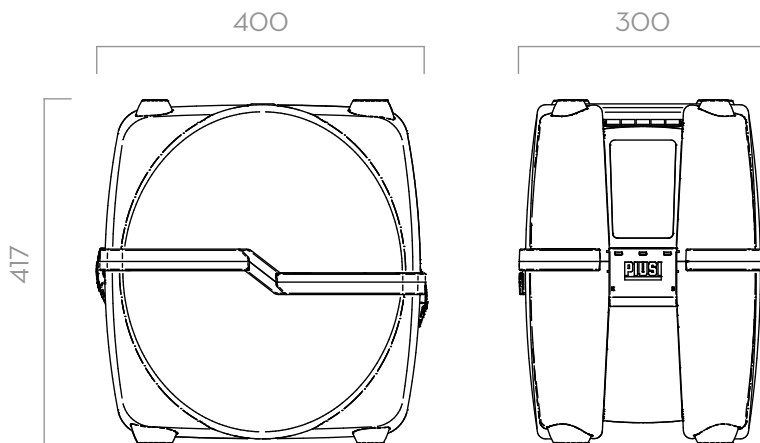

Dimensions expressed in millimeters

MATERIALS

- PUMP:
BODY: POLIPROPYLENE
DIAPHRAGM: POLIPROPYLENE

TECHNICAL DATA

CODE	DESCRIPTION	FLUIDS TYPE	FLOW RATE		VOLTAGE			RPM	DUTY CYCLE		CABLE	SUCTION HOSE 12 MM Ø	DELIVERY HOSE 12 MM Ø
			L/MIN	GPM	AC V/ HZ	DC VOLT	POWER WATT		AMP. MAX.	RPM		MIN	LENGHT (M)
FOO201R20	PIUSIBOX CAR SUCTION ADBLUE	Ad W	34	9	230/50	400	1,95	1450	20	YES	2	2	

PIUSIBOX CAR SUCTION