

K150

FEATURES

- HEAVY DUTY CONDITIONS
- HIGH FLOW RATE
- BURSTING PRESSURE 28 BAR
- EASY READING
- 4 FLOW DIRECTIONS

K150 is expressly engineered to meet the market requirements of a meter suitable for flow rates superior than 120 l/min and that can be used both for fluids such as diesel and biodiesel, as well as in potentially explosives atmosphere; with gasoline for example. K150 is easy to calibrate and ready to use; its aluminium cover and sturdy body make this meter suitable for a wide arrange of application while gua-ranteeing the same precision and quality that have always featured PIUSI equip-ment. The mechanical display allows to read quickly the quantity dispensed. It can be installed everywhere thanks to the (optional) 1,5" flange kit.

PERFORMANCE

UP TO 25-150 L/MIN FLOW RATE	3,5 BAR MAX OPERATING PRESSURE
± 1% ACCURACY	0,3% REPEATABILITY



K150



K150 BIO



PACKAGING

CODE	WEIGHT		PACKAGING			BOX/EUROPALLET	
	KG	LBS	MM	INCH	PCS/BOX	X	
FO0554A00	2,38	5,25	185X185X170	7,28X7,28X6,69	1	192	240
FO0554B00	2,38	5,25	185X185X170	7,28X7,28X6,69	1	192	240
FO0554C00	2,38	5,25	185X185X170	7,28X7,28X6,69	1	192	240
FO0554D00	2,38	5,25	185X185X170	7,28X7,28X6,69	1	192	240
FO0554B10	2,38	5,25	185X185X170	7,28X7,28X6,69	1	192	240

- ANY BIODIESEL
- AIR
- ANTIFREEZE
- AdBlue®
- BIODIESEL
- DIESEL
- FOOD
- GASOLINE
- GREASE
- KEROSENE
- OIL
- WATER
- WINDSCREEN

CHART

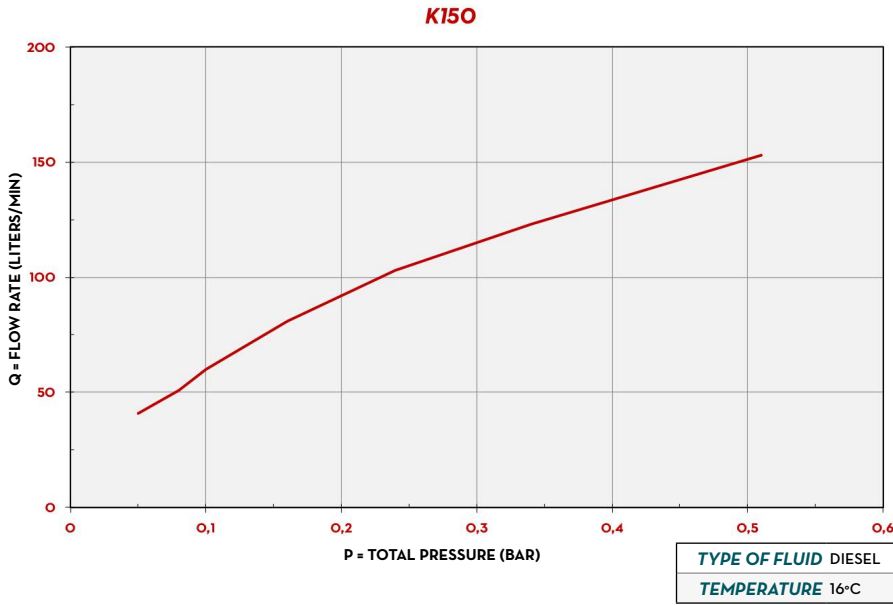

TYPE OF FLUID DIESEL
TEMPERATURE 16°C

DIMENSIONS

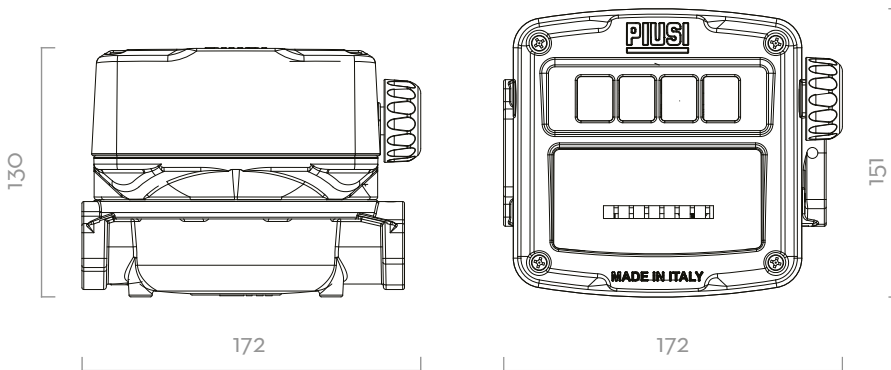

Dimensions expressed in millimeters

IN THE BOX

- K150 METER
- INSTRUCTION MANUAL

DETAILS

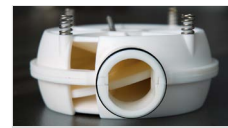

NUTATING DISK



4 FLOW DIRECTIONS



METALLIC COVER

MATERIALS

- BODY AND COVER: ALUMINIUM
- NUTATING DISK CHAMBER: TECHNOPYLIMER
- SEAL: NBR/VITON (FKM)

TECHNICAL DATA

CODE	DESCRIPTION	FLUIDS TYPE	FLOW RATE		FLOW DIRECTIONS	PRESSURE		INLET/OUTLET
			L/MIN	GPM		BAR	PSI	
FO0554A00	K150 METER LITERS - 1" BSP VER.A		25-150	6,6-40	◀	3,5	50	1" BSP
FO0554B00	K150 METER LITERS - 1" BSP VER.B		25-150	6,6-40	▲	3,5	50	1" BSP
FO0554C00	K150 METER LITERS - 1" BSP VER.C		25-150	6,6-40	▼	3,5	50	1" BSP
FO0554D00	K150 METER LITERS - 1" BSP VER.D		25-150	6,6-40	▶	3,5	50	1" BSP
NEW FO0554B10	K150 - 1" BSP VER.A B100		25-150	6,6-40	◀	3,5	50	1" BSP