

**Diesel Electropump DC, Series: SVL - Article:DETP0400**

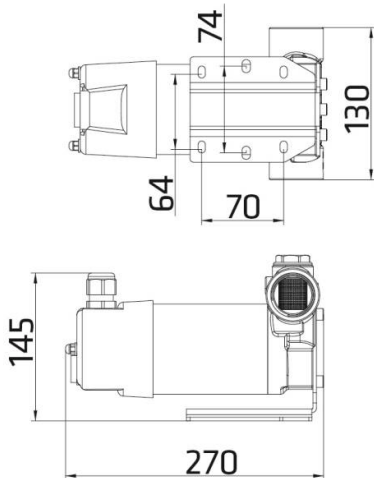
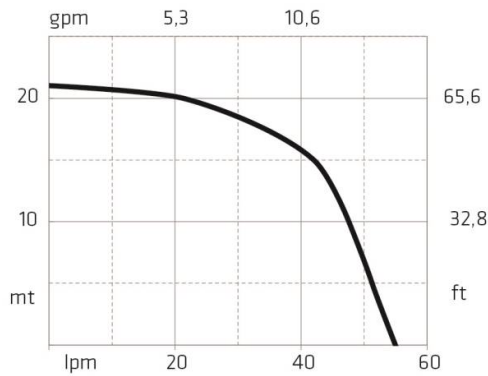
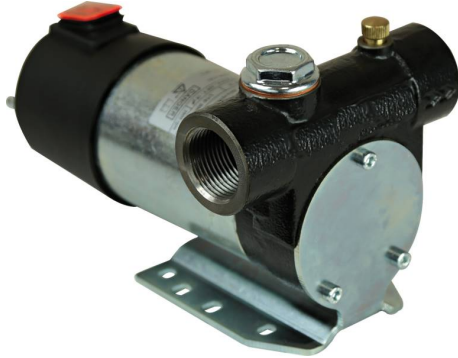

**Technical features:**

Flow rate ( 1 bar ):	47 lt/min
Voltage:	12V
Max Pressure:	2 Bar
IN:	F 1" BSP
OUT:	F 1" BSP
Suction:	2 mt
Self Priming:	Automatic
Integrated filter:	130um
Bleeder valve:	Included
Motion transmission:	Crankshaft
Type rotor:	5 vain
Pump Body:	Cast iron
By-pass:	Included
Seal:	6 bar Mechanical seal
Anti flooding motor protection:	Included
Fuse:	Amp
Duty cicle:	S2 30min
Engine Rotation :	3400 rpm
Power:	75 Watt
Ampere:	35 Amp.
Switch ON-OFF:	Optional
Electric Wire:	Optional as above
Noisiness:	80 db
Operating temperature:	+40 / -10 °C
Packaging:	32x20x17h cm
Weight:	5,2 Kg