

Includes Models
DM100-01
DM100-02
DM100-03
DM100-04
DM100-05

DM100 POSITIVE DISPLACEMENT FUEL METER



INSTRUCTION MANUAL

Introduction

Thank you for purchasing a Macnaught DM100 Positive Displacement Fuel Meter.

The Macnaught DM100 fuel meter has incorporated the oval rotor principal into its design. This has proven to be a highly reliable and highly accurate method of measuring flow, providing exceptional repeatability and high accuracy.

The low pressure drop through the meter makes the meter ideally suited for use in gravity applications or with the Macnaught range of electric fuel pumps.

Macnaught manufacture a full range of pumps, meters and accessories to suit most of your fluid transfer needs. Please consult your local Macnaught reseller for more information.

With your appropriate care combined with the Macnaught Guarantee of dependable after sales service, (provided by our worldwide distribution network), you will be assured of continuous safe, efficient and reliable product operation.

Please read and retain this instruction manual to assist you in the operation and maintenance of this quality product.

General Information

This manual assists you in operating and maintaining your new DM100 Fuel Meter. The information contained will help you ensure many years of dependable performance and trouble free operation.

Please take a few moments to read through this manual before installing and operating your new fuel meter.

If you experience problems with the product, refer to the Maintenance and Trouble Shooting sections of this manual.

If you require further assistance please contact your local Macnaught Distributor, Authorised Macnaught Service Centre or Macnaught P/L.



IMPORTANT

Macnaught recommends, that as added protection to your equipment you install a Macnaught fuel filter assembly in line before the inlet of your DM Fuel Meter. Contact your local Macnaught distributor for further details.



CAUTION

Observe precautions against fire or explosion when dispensing flammable liquid. Do not operate the meter in the presence of any source of ignition including running or hot engines, lighted cigarettes or gas or electric heaters.

Ensure that you follow all the correct earthing and grounding procedures before use.

Inspect seals and connections for leaks weekly when using flammable liquids.

Do not use Teflon tape on any connections when using flammable liquid.

Installation

1) Ensure the meter is installed so the flow of the liquid is in the direction of the arrows embossed on the meter body.

2) The meter can be installed in any orientation as long as the meter shafts are in a horizontal plane. (see fig 2 for correct installation). The register assembly may be rotated to suit the individual installation.

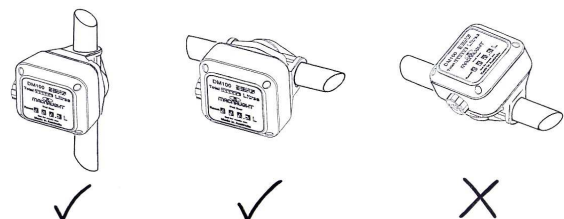

(fig 2)

Note: Incorrect installation can cause premature wear of components.

3) Do not over tighten connections.

Register rotation

- 1) Unscrew the 4 screws holding the register assembly
- 2) Carefully lift off the complete register assembly from the register base
- 3) Rotate the register assembly to the desired position.
- 4) Carefully re-fit the register assembly to the meter body.



CAUTION

Do not force the register assembly when re-fitting to the register base. Ensure that both the register drive gear and meter drive gear are properly engaged before replacing the register screws, or damage may occur.

- 5) Replace the 4 register screws.

Meter disassembly

- 1) Ensure that the fluid supply to the meter is disconnected, and the line pressure is released before disassembly.
- 2) Unscrew the 4 screws holding the register assembly.
- 3) Carefully lift off the complete register assembly from the register base
- 4) Remove the 4 gear box cover screws and carefully remove the gear box cover assembly, o'ring and gears from the gear box.

NOTE: The gear on the gear box cover assembly should not be removed. If there is any wear or damage the complete gear box cover assembly should be replaced.

- 5) Remove the 4 hex bolts holding the register base to the meter body remove the meter body o'ring and both rotors

Check all components for wear or damage and replace as required.

Meter reassembly

- 1) Clean all components before reassembly.

NOTE:

The rotor with the drive pinion must be fitted to the side of the meter body, which has D/Gear marked on the meter body, (see fig 3).

- 2) Replace the rotors so as they are at 90° to each other, (see fig 3). Check the rotor rotation by turning either of the rotors. If the rotors are not in mesh correctly or do not move freely remove one of the rotors and replace it correctly at 90° to the other rotor. Recheck the operation of the rotors.

- 3) Insert o'ring into the o'ring groove on the register base

- 4) Carefully align the spring pins on the meter body to the spring pin holes on the register base

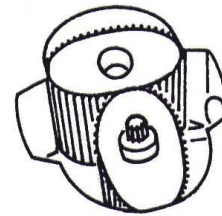

D/GEAR (fig 3)

- 5) Replace the 4 hex screws and nuts and tighten firmly.
- 6) Insert gear marked L1(Litre) or Q1 (Quart) onto the shaft located in the gear box.
- 7) Place the gear marked L2 (Litre) or Q2 (Quart) on top of gear 1. The hole in gear 2 should be positioned to align with the output shaft hole in the gear box.
- 8) Place the gear marked L3 (Litre) or Q3 (Quart) onto the same shaft as gear 1.
- 9) Insert the gearbox cover o'ring into the o'ring groove on the gear box cover
- 10) Fit the gear box cover assembly by carefully inserting the output shaft through gear 2 and into the output shaft hole in the gear box.
- 11) Fit the 4 gear box cover screws and tighten securely.
- 12) Rotate the register assembly to the desired position.
- 13) Carefully re-fit the register assembly to the meter body. Fit 4 screws and tighten firmly.
- 14) Press the reset button to reset the batch total to zero.
- 15) Test the meter by turning the rotors with a finger or by applying low air pressure. (No more than a good breath) to the inlet port of the meter. This will confirm the meter is operating correctly and that the number wheels are ascending.

DM150 Meter and Filter assembly

Note:

Order HA1s for filter assembly only

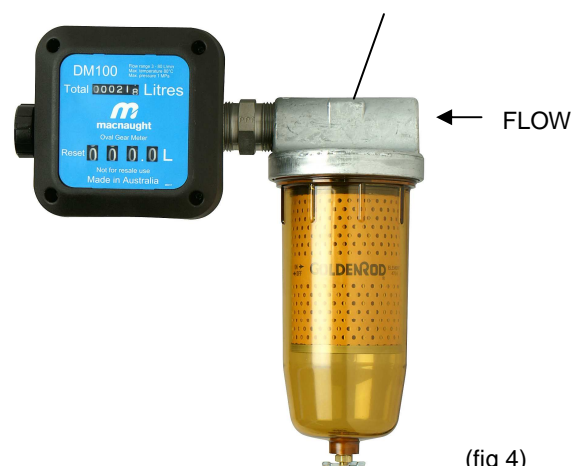

(fig 4)

Note:

Order DM150-01 for Meter and Filter assembly complete

Spare Part Diagram

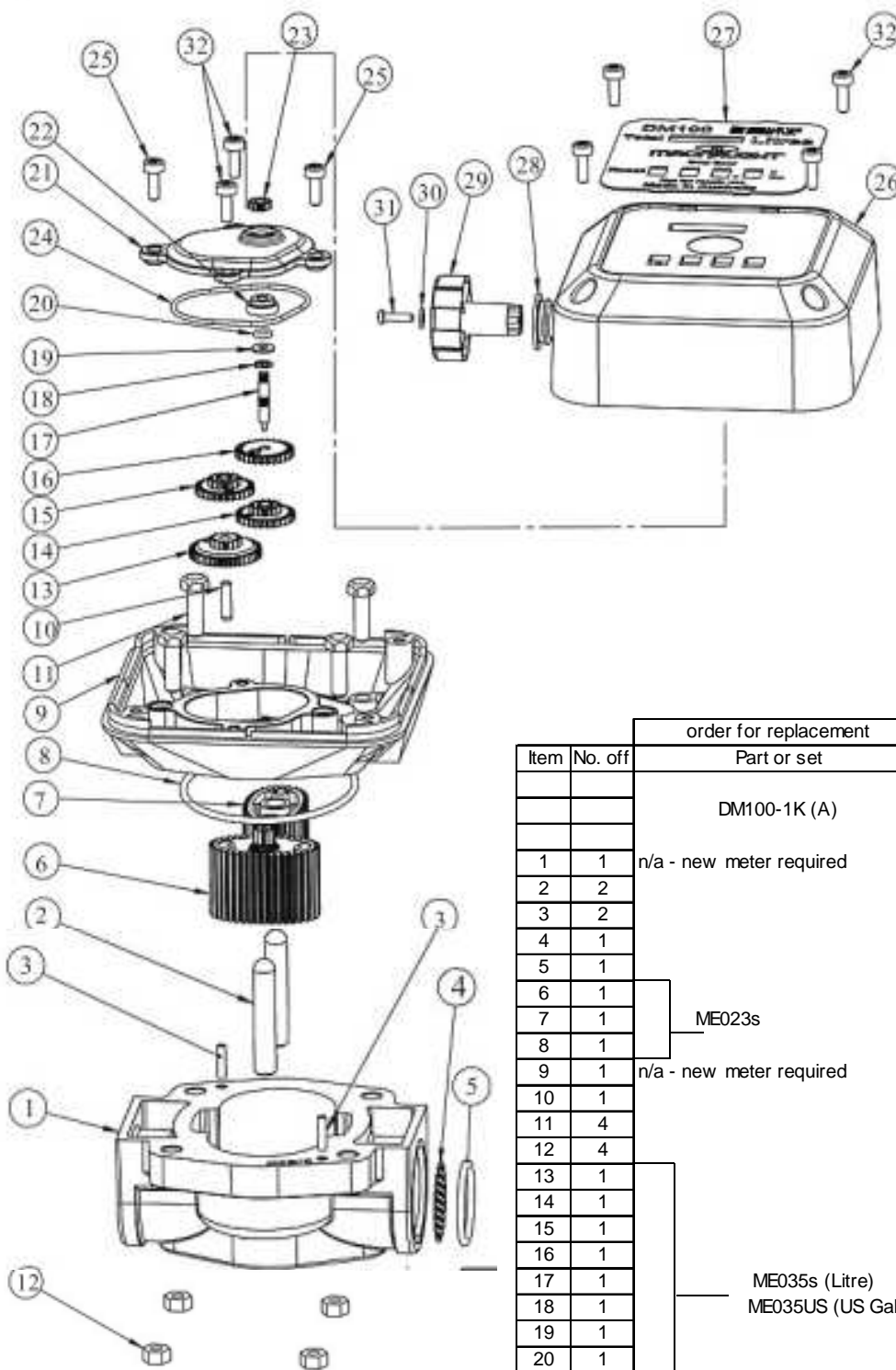

Spare Part Listing

Item	No. off	order for replacement Part or set	Kit ref	Description
		DM100-1K (A)		Seal kit
1	1	n/a - new meter required		Meter body
2	2			Dowel pins
3	2			Spring pins
4	1		A	Strainer
5	1		A	O'RING (Viton) BS121V
6	1			Rotor with drive pinion
7	1	ME023s		Rotor
8	1		A	O'ring (Viton) BS150V
9	1	n/a - new meter required		Register base
10	1			Dowel pins
11	4			Hex screw (M6 X 20)
12	4			Nut (M6)
13	1			1st Gear
14	1			2nd Gear
15	1			3rd Gear
16	1			4th Gear
17	1			Output shaft
18	1			Circlip
19	1			Washer
20	1		A	O'ring (Viton) BS007V
21	1			Gear box cover
22	1			Bush
23	1			Gear
24	1		A	O'ring (Viton) BS032V
25	2			Screw (M4 X 16)
26	1			Register assembly
27	1			Facia plate
28	1		A	Weather seal
29	1	ME025s		Knob
30	1			Washer
31	1			Screw
32	6			Screw (M4 X 12)
		ME041s (Litre) ME041US (US Gal)		

Troubleshooting Guide

TROUBLE	CAUSE	REMEDY
Fluid will not flow through the meter	a) Foreign matter blocking the rotors (6,7)	a) Dismantle the meter and clean the rotors (6,7) (Fit an in line strainer)
	b) Strainer (4) is blocked	b) Clean strainer (4)
	c) Damaged rotors (6,7)	c) Replace rotors (6,7)
	e) Connections over tightened	e) Re-adjust connections
Reduced flow through the meter	Strainer partially blocked (4)	Clean strainer (4)
Meter reading inaccurate	a) Flow rate is either too high or too low	a) Adjust flow rate (refer to specifications)
	b) Excess wear caused by incorrect installation	b) Check meter body (1) register base (9) and rotors (6,7) for wear or damage.(Replace as required)
Fluid flows but no reading on the meter	a) Drive gear loose (23)	a) Replace gear box cover assembly (16-23)
	b) Rotor (6) drive gear damaged	b) Replace rotor (6)
	c) Gearbox gears (13-16) damaged	c) Replace damaged gears
	d) Register gears damaged	d) Replace register assembly
Fluid leaks into the register assembly	Damaged o'ring (20) or o'ring (24)	Replace gear box cover assembly (13-23) or o'ring (24)

Product Specifications

Accuracy	+/- 1" of Reading
Type	Oval Gear
Flowrate	3 - 80 Litre/min (0.8-21 US Gal/min)
Maximum Pressure	345kPa / 50psi / 3.45 Bar
Suitable for use with	Diesel, Kerosene, Petrol and Oils up to 1000cps.
Reset-able Totalizer	999.9 Lt or Gal
Non-Reset-able Total	999999 Lt or Gal
Wetted Components	Aluminium, Mild Steel, Brass
	Acetal, Viton, Polyetherimide Resin
Port Threads	1" Rp
	1" NPT
	1" BSP.F (G)
Minimum Gravity Head	550mm



Macnaught Pty Limited

ABN 66 000 075 785

41-49 Henderson Street
Turrella NSW 2205 Sydney Australia
Postal Address PO Box 90
Arncliffe NSW 2205 Sydney Australia

T: +61 2 9567 0401

F: +61 2 9597 7773

W: www.macnaught.com.au

**For Warranty Terms and Conditions see macnaught.com.au
For a list of Australian Service Centres see macnaught.com.au**