

Diesel Electropump DC, Series: TOM 100 DC - Article:DETP0812

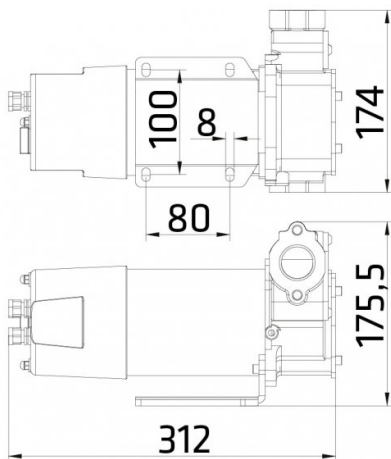

BATTERY PERFORMANCE NECESSARY
12v 70Ah

PERFORMANCE

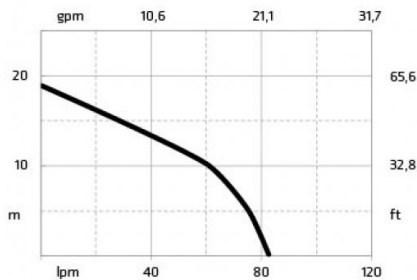

Technical features:

Flow rate (1 bar) :	61 lt/min
Voltage :	12V
Max Pressure :	1,8 Bar
IN :	F 1" BSP
OUT :	F 1" BSP
Suction :	3,5 mt
Self Priming :	Automatic
Engine Rotation :	3500 rpm
Power :	300watt
Ampere :	60 Amp.
Integrated filter :	Impurity 130 micron
Bleeder valve :	Included
Motion transmission :	Crankshaft
Type rotor :	6 Vanes
Pump Body :	Cast iron
By-pass :	Included
Seal :	6 bar Mechanical seal NBR
Switch ON-OFF :	Included
Electric Wire :	Clamp wire 1,8mt
Battery performance necessary :	12v 70Ah
Fuse :	70 Amp
Operating temperature :	+40 / -10
Compatible Liquids :	Diesel
Duty cycle :	S2 30min
Packaging :	34x18x26h cm
Weight :	11,3 Kg