

IMPORTANT: READ BEFORE USING

INSTALLATION AND OPERATING INSTRUCTIONS STAINLESS STEEL ROTARY DRUM PUMP

Description

This Stainless Steel Rotary Hand Pump is commonly used for aggressive chemicals, such as Esters, Alcohols, Alkali, Strong Acids, Hydrocarbons that are compatible with pump materials of construction. Also suitable for transferring Petroleum based fluids, such as Automotive Additives, Diesel, Lube Oils, Kerosene, Solvents, Thinner, Benzene, Cleaning Solutions, Fuel Oils, Transmission Fluid, and water based chemicals, Anti-Freeze, Soaps, Waxes, Edible Liquids, etc. Supply with 2" bung adapter and a 3-piece stainless steel suction tube to fit most 15, 30 and 55 gallon drums.

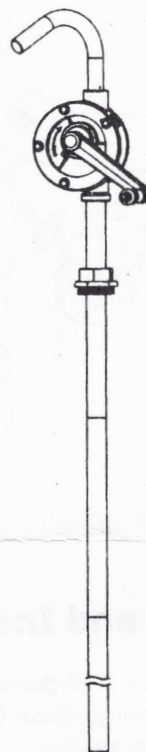

Specifications

Pump Type.....	Rotary - Vane
Flow.....	12 oz / Stroke
Maximum Fluid Temperature.....	130°F / 54°C
Bung Adapter.....	2" Male
Suction Tube Length.....	40" Maximum
Inlet.....	1-1/4" O.D.
Outlet.....	1" O.D. Curved Spout
Wetted Materials of Construction	304SS, PVDF, VITON
Maximum Viscosity.....	2,000 SSU

General Safety Information

1. Always carefully read, thoroughly understand and follow the pump operating instructions. Use this pump correctly and with care for the purpose for which it is intended. Failure to do may cause damage or personal injury, and will invalidate the warranty. Retain instructions for future reference.
2. Contact your chemical or fluid supplier to check for compatibility with pump prior to installation and operation.
3. Prior to use, always carefully and thoroughly read and understand the OSHA information contained in the Safety Data Sheet supplied for the chemical which is to be pumped.
4. Wear protective clothing (goggles, face masks, long sleeves, long pants, gloves, aprons, etc.) as set forth in the OSHA Safety Data Sheet when pumping any hazardous chemicals.
5. When using flammable liquids, pump containers should be grounded to avoid static electricity.
6. Any pump used for transferring flammable liquids must be stored in a ventilated area after use.
7. Pump should be washed out before it is used since processing lubricants may contaminate the fluids.
8. Prior to use, inspect your pump thoroughly verifying its proper assembly.
9. If pump is removed from drum, it should be thoroughly rinsed in a liquid that is compatible with both the pump and fluid.

Repair Parts Illustration

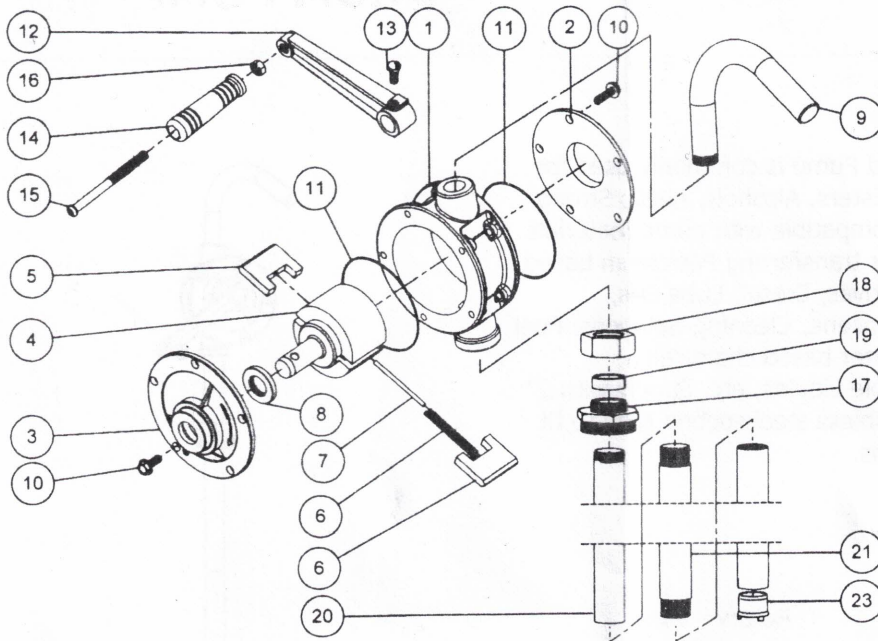

Repair Parts List

Ref No.	Description	Qty
1	Pump Body	1
2	Rear Cover	1
3	Front Cover	1
4	Rotor	1
5	Vane	2
6	Spring	1
7	Spring Rod	1
8	Lip Seal	1
9	Discharge Spout	1
10	Cap Screw	10
11	O-Ring	2
12	Crank Arm	1
13	Set Screw	1
14	Handle	1
15	Handle Shaft	1
16	Hex Bridge	1
17	Bung Adapter	1
18	Fixed Nut	1
19	Fixed Ring	1
20	Suction Tube	1
21	Suction Tube	1
22	Suction Tube	1
23	Suction Filter	1

Assembly and Installation

1. Check to see if all parts are included.
2. Screw discharge spout (Ref No. 9) into pump body (Ref No. 1) outlet using PTFE sealant tape provided. Do not use pipe sealant.
3. Screw handle assemble to crank arm (Ref No. 12) using the hex nut (Ref No. 16) supplied. Keep handle shaft from turning. Tighten hex nut against crank arm. Then insert crank arm assembly onto pump shaft, taking care to align set screw (Ref No. 13) to indent in rotor (Ref No. 4).
4. In order to avoid leakage, please use PTFE tape provided to seal three suction tubes (Ref No. 20+21+22). Insert the bung adapter (Ref No. 17+18+19) into suction tube (Ref No. 20) and thread suction tube (Ref No. 20) into pump inlet. Thread suction tube (Ref No. 21) into suction tube (Ref No. 20). Thread suction tube (Ref No. 21) into suction tube (Ref No. 22).
5. Insert pump and suction tube assembled with bung adapter into the drum, and then tighten bung adapter thumb screw (Ref No. 20) by hand. Be sure to set pump and suction tube assembly so that the suction tube is at the desired depth in the drum and is not blocked.

Operation

1. To begin pumping fluid, rotate handle clockwise several times making complete revolutions until fluid begins to flow. Several revolutions will be made with no fluid dispensed as pump needs to prime. Once primed, fluid flow begins as handle is rotated.
2. For siphoning or draining fluid back into drum, place handle in the straight down position.
3. To stop siphoning and maintain suction or prime, leave handle in horizontal position.
4. If corrosion builds up in pump due to lack of use or fluid being pumped, adding penetrating oil into the pump inlet may help free pump. Remove pump from application, add penetrating oil, let soak, and then crank several times.
5. Regularly check pump and suction tubes for leaks. Leaks in the suction line or in pump housing will cause inefficient pumping and loss of prime.